

# DTWRX

## TELEMETRY RECEIVER FOR WIPER CONTROL

REVISION 0945



### MAIN FEATURES

Control of wiper and washer pump

RS485 communication

Remote control up to 1200m (3937ft, RS485) from the control keyboard

Easy installation

### DESCRIPTION

The DTWRX is an optional board for remote control of wiper and washer pump. It works only with UPTWAS pump series, where it can be easily installed thanks to its connector. It allows the control of wiper and washer function when the housing is stand-alone, not mounted on a P&T and then without telemetry receiver.



DTWRX



UPTWAS + DTWRX

DTWRX

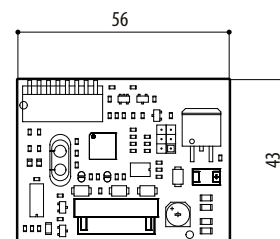

## DTWRX

## TECHNICAL DATA

## GENERAL

2 functions: WIPER, WASHER  
 32 selectable address through Dip Switch  
 Serial input RS485  
 LED indicating stand-by status  
 LED indicating command reception  
 Supplied with instruction manual

## MECHANICAL

External dimensions: 43x56x13mm (1.8x2.2x0.5in)

## ELECTRICAL

Power consumption: 0.5W

## PROTOCOLS

MACRO (9600, 38400 Baudrate)

PELCO D (9600, 2400 Baudrate)

*PELCO is a registered trademark.*

*Because DTWRX may be interfaced with equipment not manufactured by VIDEOTEC, it is possible that the interface protocols have changed or are in a different configuration from earlier tested units from us. Because VIDEOTEC recommends a bench test prior to installation, VIDEOTEC will not be liable for any installation costs or lost revenues in the event a compatibility problem will occur.*

## COMMUNICATIONS

Telemetry data input RS485 on keyboards serial output for a max distance of 1200m (3937ft)

Telemetry data input RS485 on matrix SM series serial output for a max distance of 1200m (3937ft)

## ENVIRONMENT

Indoor / Outdoor

Operating temperature: -30°C / +50°C

## CERTIFICATIONS

CE EN60950-1, EN50130-4, EN55022 Class B

FCC Part 15 Class B (only with UPTWAS02C)

## RELATED PRODUCTS

UPTWAS01C	Tank 23l (6gal), 230Vac washer pump
UPTWAS02C	Tank 23l (6gal), 24Vac washer pump
UPTWASA01C	Tank 23l (6gal), 230Vac washer pump, high delivery up 30m (98ft)
DCTEL	Keyboard to control matrix and telemetry
DCJ	Keyboard to control matrix, multiplexers and telemetry equipped with three axis joystick
DCT	Touch screen keyboard to control matrix, multiplexers, DVRs and telemetry equipped with three axis joystick
HEG, HOV	Standard housings equipped with wiper
NXM, NXJ, NXL	Stainless steel housings equipped with wiper

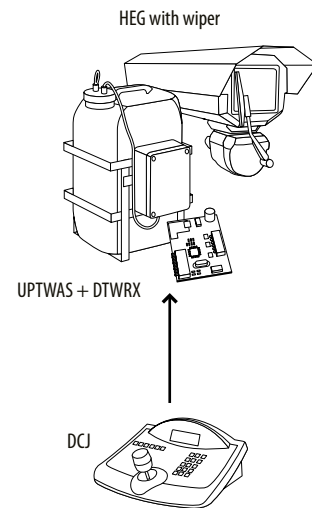

→ Twisted pair RS485 (max distance 1200m / 3937ft)

## PACKAGE

Code	Unit weight		Package weight		Package dimensions (WxHxL)		Master carton unit
	kg	lb	kg	lb	cm	in	
DTWRX	0.02	0.04	-	-	8.5x5.5x11.5	3.3x2.2x4.5	-