

LM SERIES

Micro PLC

Hardware Manual



Contents

Chapter 1 LM Micro PLC Overview	5
1.1 Overview	5
1.2 Hardware System Architecture	5
1.2.1 CPU Modules	6
1.2.2 Expansion Modules	8
1.2.3 Maximum I/O Configuration	8
1.3 Communication Function	9
1.4 Quick Usage Guide	10
1.4.1 PLC Products Check	10
1.4.2 Power Supply Wiring	10
1.4.3 Creating PC Communication	11
1.4.4 Control Programming	11
1.4.5 Run	12
Chapter 2 CPU Modules	13
2.1 Overview	13
2.1.1 CPU Architecture	13
2.1.2 CPU Features	14
2.1.3 Run Mode	15
2.1.4 Work State Indicator Lights	16
2.1.5 Communication Interface	17
2.2 8-channel DI/6-channel DO CPU Module LM3104	17
2.2.1 Technical Specifications	17
2.2.2 LM3104 Terminal Definition and Wiring	19
2.2.3 LM3104 Communication Function	21
2.2.4 LM3104 Equivalent Circuit	21
2.2.5 LM3104 Software Configuration	22
2.3 8-channel DI/6-channel DO CPU Module LM3105	24
2.3.1 Technology Specifications	24
2.3.2 LM3105 Terminals Definition and Wiring	26
2.3.3 LM3105 Communication Function	27
2.3.4 LM3105 Equivalent Circuit	28
2.3.5 LM3105 Software Configuration	28
2.4 14-channel DI/10-channel DO CPU Module LM3106	29
2.4.1 Technical Specifications	29
2.4.2 LM3106 Terminals Definition and Wiring	31
2.4.3 LM3106 Communication Function	34
2.3.4 LM3106 Equivalent Circuit	34
2.3.5 LM3106 Software Configuration	34
2.5 14-channel DI/10-channel DO CPU Module LM3106A	35
2.5.1 Technical Specifications	35
2.5.2 LM3106A Terminals Definition and Wiring	37



2.5.3	LM3106A Communication Function	40
2.5.4	LM3106A Equivalent Circuit.....	40
2.5.5	LM3106A Software Configuration	40
2.6	8-channel DI/6-channel DO CPU Module LM3107	41
2.6.1	Technical Specifications	41
2.6.2	LM3107 Terminals Definition and Wiring	43
2.6.3	LM3107 Communication Function	44
2.6.4	LM3107 Equivalent Circuit	44
2.6.5	LM3107 Software Configuration	44
2.7	24 Channel DI/16 Channel DO CPU Module LM3108.....	45
2.7.1	Specifications	45
2.7.2	LM3108 Terminal Definition & Wiring	47
2.7.3	LM3108 Communication Function.....	49
2.7.4	LM3108 Equivalent Circuit	50
2.7.5	LM3108 Software Configuration	50
2.8	24 Channel DI/16 Channel DO CPU Module LM3109.....	50
2.8.1	Specifications	50
2.8.2	LM3109 Terminal Definition & Wiring	52
2.8.3	LM3109 Communication Function.....	54
2.8.4	LM3109 Equivalent Circuit	54
2.8.5	LM3109 Software Configurations	54
	Chapter 3 Expansion Modules	55
3.1	Digital Expansion Modules.....	56
3.1.1	8 Channel Digital Input Module LM3210.....	56
3.1.2	8 Channel AC DI Module LM3211	58
3.1.3	16 Channel DI Module LM3212.....	60
3.1.4	8 Channel Transistor Output Module LM3220.....	61
3.1.5	16 Channel Transistor Output Module LM3221.....	64
3.1.6	8 Channel Relay Output Module LM3222.....	65
3.1.7	16 Channel Relay Output Module LM3223.....	68
3.1.8	4 Channel DI/4 Channel Transistor Output Module LM3223	69
3.1.9	4 Channel DI/4 Channel Relay Output Module LM3231	71
3.2	Analog Expansion Modules	73
3.2.1	4 Channel Analog Input Module LM3310.....	73
3.2.2	4-Channel Analog Input Module LM3310A.....	78
3.2.3	4-Channel Analog Input Module LM3310B.....	81
3.2.4	4 Channel Thermocouple Input Module LM3311	85
3.2.5	4 Channel RTD Input Module LM3312.....	89
3.2.6	8-Channel Analog Input Module LM3313.....	92
3.2.7	8 Channel Thermo Sensitive Input Module LM3314	94
3.2.8	2 Channel Analog output Module LM3320	96
3.2.9	4 Channel Analog Input/1 Channel Analog Output Module LM3330.....	100
3.3	Special Function Expansion Modules	102
3.3.1	4 Profibus-DP Slave Station Module LM3401	102

3.3.2 Ethernet Interface Module LM3403.....	105
Chapter 4 Installation	108
4.1 Guidance Principle	108
4.1.1 Ventilation.....	108
4.1.2 Cable Location Properly.....	109
4.2 Electrical Safety	110
4.2.1 Restraining loop	110
4.2.2 Emergency Shutdown	111
4.3 Installation & Disassembly	111
4.3.1 Installation Mode.....	111
4.3.2 Connect Expansion Cable	115
4.3.2 Terminal Wiring.....	115
4.4 Dimension structure	117
Appendix	119
A、LM Series Micro PLC Products Oder List	119
B、LM Series Micro PLC General Technology Specification.....	121



Chapter 1 LM Micro PLC Overview

1.1 Overview

LM Micro PLC can realize the strong and complex control function no matter it works under independent mode or network mode. Main features of the PLC product are

- Compact size
- Instruction set with strong functions
- Simple and safe installation
- Unique power off protection
- Various hardware modules
- Off-line simulation
- Strong analog signal processing ability
- Standard program languages

The LM Micro PLC application domains include machine tool, punch mechanism, print mechanism, spin mechanism, building material mechanism, packaging mechanism, plastic mechanism, motion control, transmission line, environmental protection equipment, central air condition, lift control, latex industry and various production lines etc.

1.2 Hardware System Architecture

LM Micro PLC consists of CPU modules and various expansion modules. CPU module can work independently; if the I/Os of the CPU module can not meet the system requirements, CPU module can work under expansion mode, which CPU connecting with expansion modules by expansion cable. If special network communication is required, CPU can work by connecting with special communication expansion modules. The LM Micro PLC hardware and work system architectures are shown in Figure 1.2.1 and Figure 1.2.2 respectively.

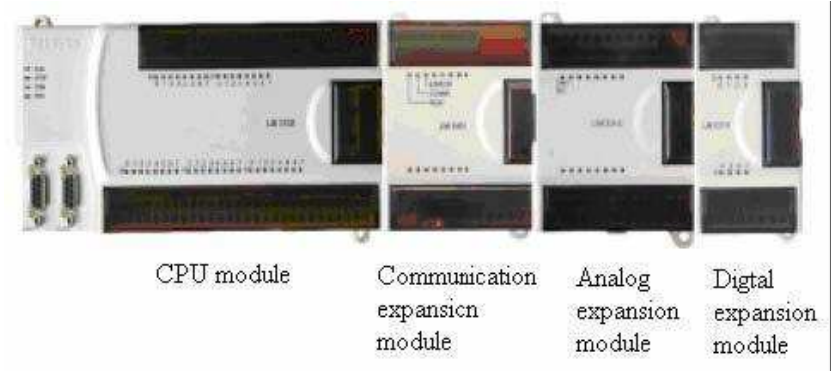

Figure 1.2.1 Hardware System Architecture

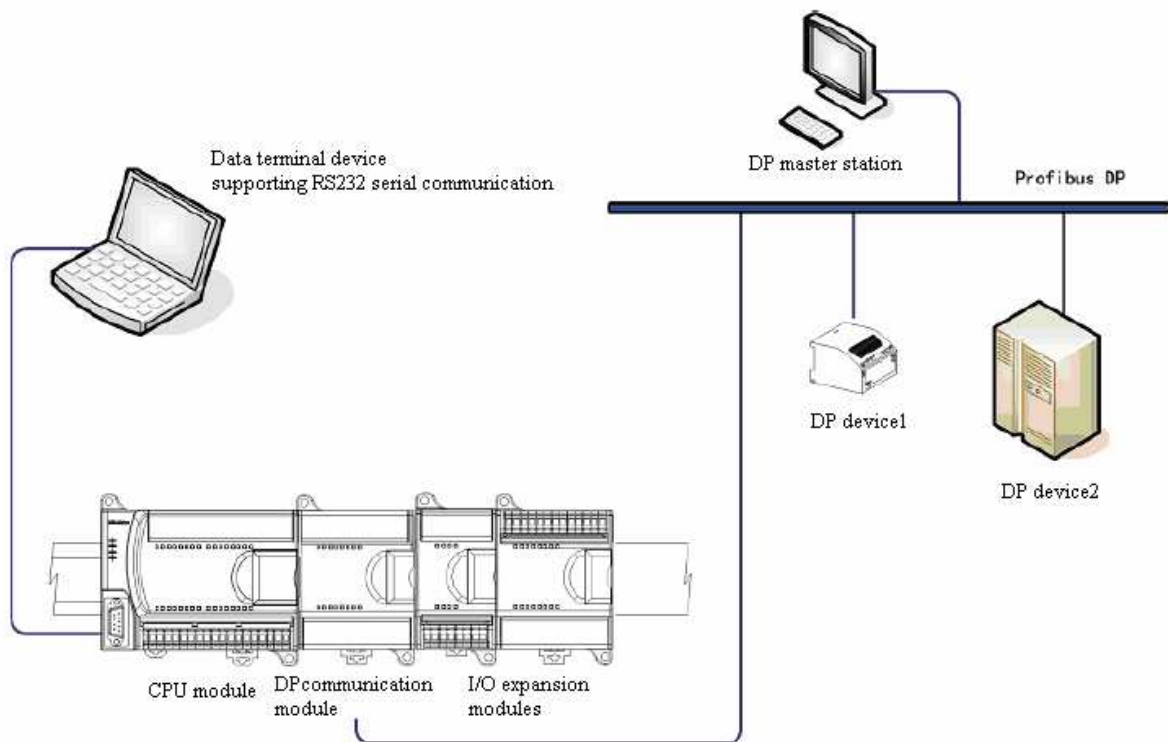









Figure 1.2.2 LM Micro PLC Work System Architecture

1.2.1 CPU Modules

CPU module executes the job cycle such as “Read input data → Execute Program → Process communication requirement → Self diagnostic → Write output data”. LM Micro PLC CPU module is available in 7 types.

Table 1.2.1 LM Micro PLC CPU Modules

CPU model	CPU module	Specifications Description
LM3104		<p>8×DI, 6×DO (transistor), 2 expansion modules (DP slave station interface module LM3401 and Ethernet interface module LM3403 can not be connected with LM3104). Three 100KHz single-phase counters / two 100KHz two-phase counters, one 20KHz high-speed pulse output. One RS232 serial port; support proprietary, MODBUS RTU slave and free protocols.</p>
LM3105		<p>8×DI, 6×DO (relay), 2 expansion modules (DP slave station interface module LM3401 and Ethernet interface module LM3403 can not be connected with LM3105). Three 100KHz single-phase counters / two 100KHz two-phase counters. One RS232 serial port; support proprietary, MODBUS RTU slave and free protocols.</p>
LM3106		<p>14×DI, 10×DO (transistor), 4 expansion modules. Three 100KHz single-phase counters / two 100KHz two-phase counters, two 20KHz pulse outputs. One RS232 serial port; support proprietary, MODBUS RTU slave and free protocols.</p>
LM3106A		<p>14×DI, 10×DO (transistor), 4 expansion modules. Three 100KHz single-phase counters / two 100KHz two-phase counters, two 100KHz pulse outputs. One RS232 serial port; support proprietary, MODBUS RTU slave and free protocols. Designed for motion control.</p>
LM3107		<p>14×DI, 10×DO (relay), 4 expansion modules. Three 100KHz single-phase counters / two 100KHz two-phase counters. One RS232 serial port; support proprietary, MODBUS RTU slave and free protocols.</p>
LM3108		<p>24×DI, 16×DO (transistor), 7 expansion modules. Three 100KHz single-phase counters / two 100KHz two-phase counters, two 20KHz pulse outputs. One RS232 serial port and one RS485 serial port. Support proprietary, MODBUS RTU slave and free protocols.</p>
LM3109		<p>24×DI, 16×DO (relay), 7 expansion modules. Three 100KHz single-phase counters / two 100KHz two-phase counters. One RS232 serial port and one RS485 serial port. Support proprietary, MODBUS RTU slave and free protocols.</p>

1.2.2 Expansion Modules

LM Micro PLC expansion modules include I/O expansion modules and communication expansion modules (Profibus-DP slave interface module and Ethernet interface module). Figure 1.2.3 shows the combination of LM Micro PLC CPU and expansion modules.



Figure 1.2.3 Combination of LM Micro PLC CPU and Expansion Modules

1.2.3 Maximum I/O Configuration

Table 1.2.3 Maximum I/O configuration of One CPU Module

PLC Modules	DI	DO	AI	AO
LM3104/LM3105				
CPU I/O	8	6		
Maximum DI/O	8+64	6+64		
Maximum AI/O			16	4
LM3106/LM3106A/LM3107				
CPU I/O	14	10		
Maximum DI/O	14+128	10+128		
Maximum AI/O			32	8
LM3108/LM3109				
CPU I/O	24	16		
Maximum DI/O	21+224	16+224		
Maximum AI/O			56	14

1.3 Communication Function

◇ Serial Communication

RS232 and RS485 serial communication ports are integrated on CPU modules; support proprietary, standard Modbus RTU and free protocols.

◇ Field Bus

LM3401, communication expansion module, is Profibus-DP slave interface module. G3 series PLC can be connected to Profibus-DP field bus network using LM3401; the communication speed is adaptive up to 12Mbps and the input/output area size is 64bytes.

◇ Industrial Ethernet Network

LM3403, communication expansion module, is Ethernet interface module and supports standard Modbus TCP protocol. LM Micro PLC can connect to Ethernet network using LM3403; the communication speed is 10Mbps, and input/output area size is 200bytes.



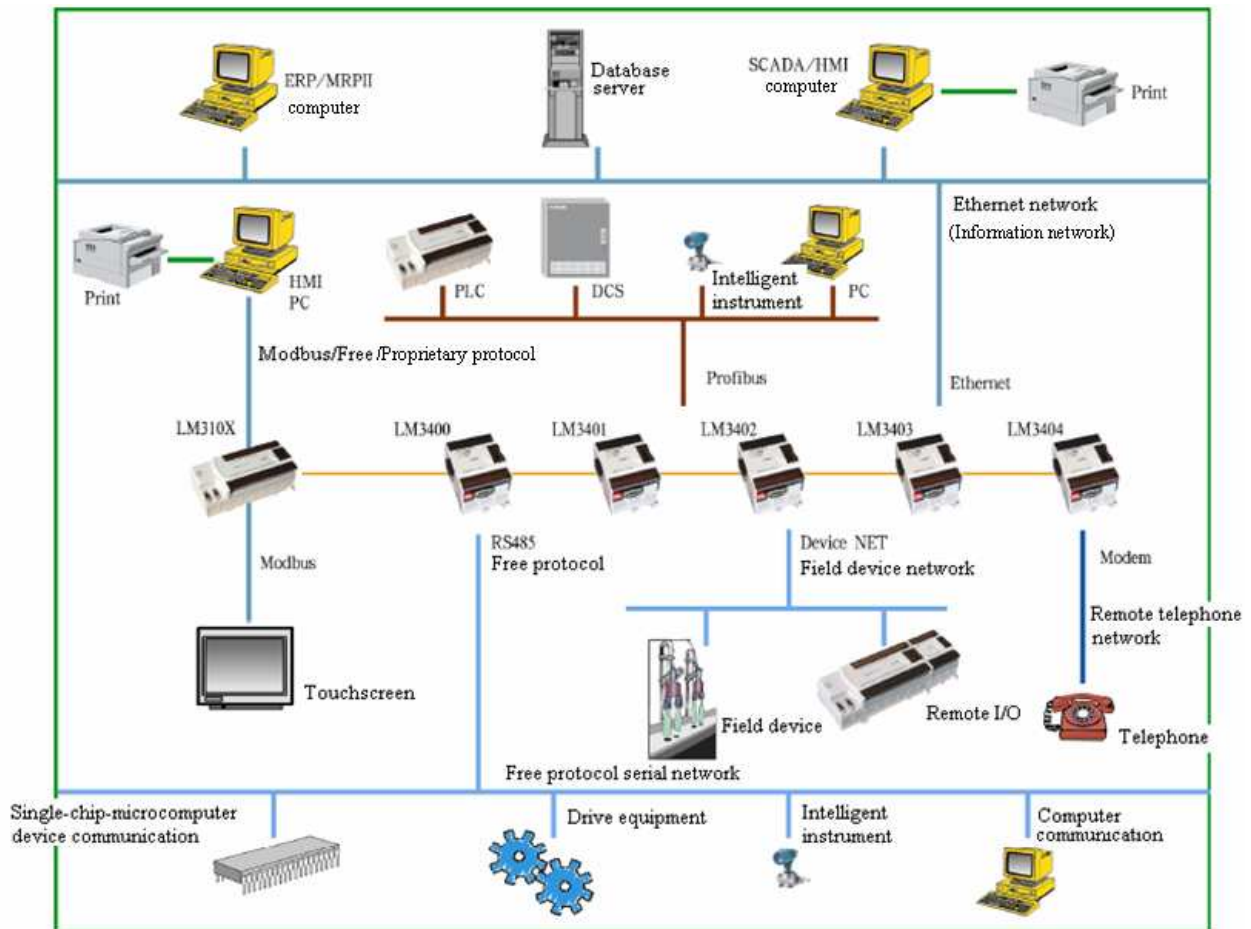

Figure 1.3.1 Communication Network Architecture

1.4 Quick Usage Guide

If you already have the PLC usage experiences, the following instructions will help you to create a simple LM Micro PLC control system quickly.

1.4.1 PLC Products Check

Confirm that the PLC products you got are the same with what you ordered, check packaging integrity. If the packaging or the PLC products are damaged, please contact the supplier as soon as possible.

1.4.2 Power Supply Wiring

Power supply wiring (please see the details in Chapter 4) is shown in Figure 1.4.1.

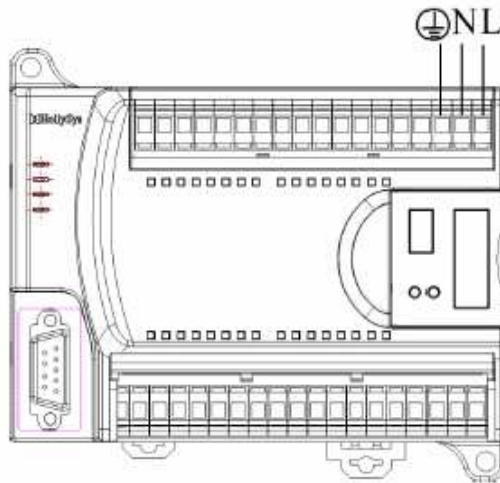

Figure 1.4.1 Power Supply Wiring

After finishing the power supply wiring, please do not power-on PLC immediately. Check the wiring and being sure that all wiring is correct, and then power-on PLC, RUN indicator light is ON.

i After finishing the power supply wiring, please cover the terminal lid to avoid unnecessary person injury and equipment damage!

1.4.3 Creating PC Communication

Please connect CPU module with PC by LM PLC programming cable before the PLC power-on, because the RS232 communication port on CPU module is non-isolated

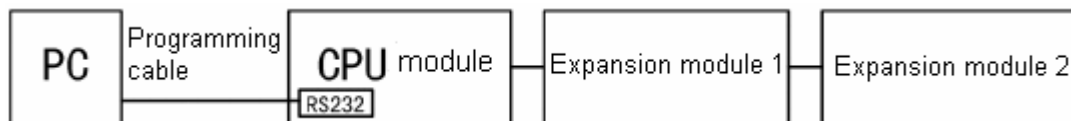

Figure 1.4.2 Programming Cable Connection

1.4.4 Control Programming

Install PowerPro, program software, on your PC, create the communication between PowerPro and CPU module and set the relative hardware parameters; according to the engineering requirements, design and develop the PLC application program to meet your control demand.

1.4.5 Run

Insure that all the producers above are done correctly, download the control program having been debugged into PLC, finish field debugging. The control system based on the LM Micro PLC can run.



Communication interface module can not be swapped under power-on!

Chapter 2 CPU Modules

2.1 Overview

2.1.1 CPU Architecture

CPU module architecture is shown in Figure 2.1.1, which includes analog potentiometer, expansion interface, run selection switch, state indicator light, input/output wiring terminals, channel indicator light, communication interface, heat dissipation holes, mounting holes, rail fastener, etc.

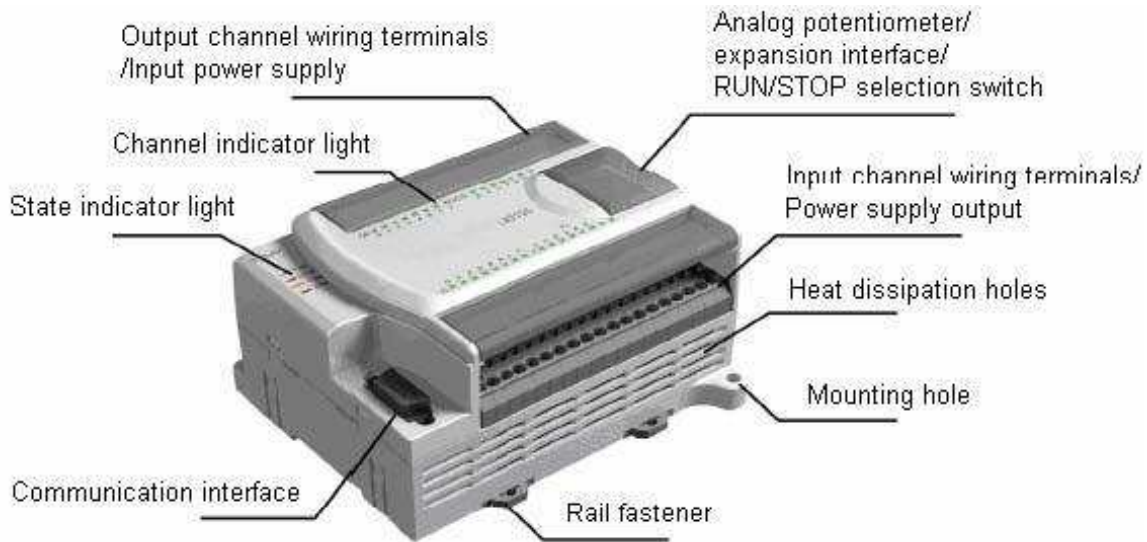

Figure 2.1.1 CPU Module Architecture

- ◇ “RUN/STOP selection switch” is used to select CPU module run mode.
- ◇ Analog potentiometer is used to Set-point Value during customer debugging.
- ◇ Expansion interface is used to the high-speed data transmission between CPU module and expansion modules.

2.1.2 CPU Features

LM Micro PLC provides kinds of CPU modules to meet different application requirements. DIs and Dos integrated with CPU modules. DI is transistor input and can connect with source/sink input signal; DO is transistor/relay output. The power supply of the CPU module is 24V DC/220V DC. Table 2.1.1 shows the CPU main features.

Table 2.1.1 CPU Main Features

	LM3104	LM3105	LM3106/ LM3106A	LM3107	LM3108	LM3109
Power supply voltage	24VDC	220VAC	24VDC	220VAC	24VDC	220VAC
DI	8×24VDC	8×24VDC	14×24VDC	14×24VDC	24×24VDC	24×24VDC
DO	6×Transistor	6×Relay	10×Transistor	10×Relay	16×Transistor	16×Relay
24V DC output	300mA	200mA	300mA	200mA	400mA	
Program memory	28K bytes		120K bytes			
Input memory	256 bytes		512 bytes			
Output memory	256 bytes		512 bytes			
M memory	4K bytes		8K bytes			
Random memory	12K bytes		24K bytes			
Retain area	No		6K bytes			
Timers	Super long time (minimum 1ms, maximum 49 days); no quantity limit					
Counters	No quantity limit					
Password	Yes					
Real-time clock	No		Yes			
Real-time clock power off retain time	No		10 days			
Application program power off retain time	10 years					
Calculation speed	0.37μs (Single Boolean instruction)					
Program language	Comply with IEC61131-3 international standard, support various program languages: Ladder Diagram (LD), Instruction List (IL), Function Block Diagram (FBD), Sequential Function Chart (SFC), Structured Text (ST) and Continuous Function Chart (CFC).					
Basic instructions	340					
Expansion instructions	47					
Communication interface	RS232 (non-isolation)				RS232 (non-isolation) RS485 (non-isolation)	

Basic Performances	LM3104	LM3105	LM3106/ LM3106A	LM3107	LM3108	LM3109
Interruption inputs (falling-edge-triggered and rising-edge-triggered are optional)	2		4			
Pulse catch inputs (falling-edge-triggered and rising-edge-triggered are optional)	2		4			
High-speed counter	3 monophase counters, 100KHz					
	2 biphas counters, 100KHz					
High-speed output (transistor only)	1 output		2 outputs			
	Pulse train output (PTO), Pulse wide modulation (PWM)					
	Output frequency: 20KHz (LM3106A, PWM: 100KHz PTO: 50KHz)					
Maximum expansion modules	2 modules		4 modules		7 modules	
Dimensions	125mm(L)×90mm(W)×70mm (H)				200mm(L)×90mm(W)×70mm (H)	

2.1.3 Run Mode

Table 2.1.2 RUN/STOP Selection Switch Description

Switch State	Description
RUN	CPU module under run mode, execute application program.
STOP	CPU module does not execute application program and it is allowed to download application program into CPU module.

 Only under STOP mode, download application program into CPU module is allowed.

2.1.4 Work State Indicator Lights

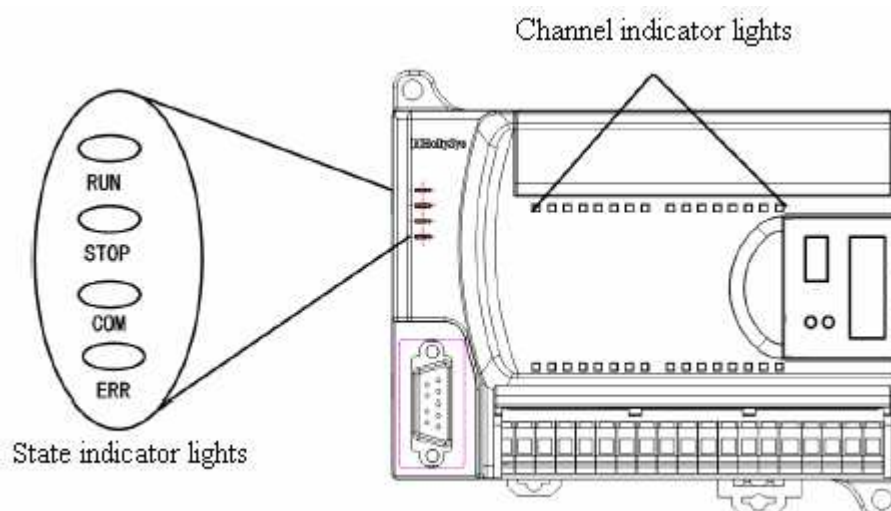

Figure 2.1.2 Indicator Lights Diagram

- ◇ Channel indicator lights: indicate the work state of each channel (DI/DO) of the CPU module;
- ◇ Work state indicator light (RUN/STOP): indicator CPU module run state (run/stop);
- ◇ Communication indicator light (COM): indicate PLC system communication state, which includes the data frame receiving and sending;
- ◇ Error indicator light (ERR): indicate the errors self-diagnosed by PLC system.

Table 2.1.2 Indicator Lights Definition

		State	Meaning
Channel indicator lights (green)		ON	Signal input or output
		OFF	No signal input or output
Working state indicator lights	RUN (green) STOP (yellow)	RUN is ON STOP is OFF	CPU module works normally, application program is running.
		RUN is OFF STOP is ON	CPU module works normally; application program is not running or no application program in CPU module.
		RUN is OFF STOP is OFF	CPU module power off or CPU module failed.
		RUN is ON STOP is OFF	CPU module failed.
Communication indicator light COM (green)		Flashing	CPU module is doing communication.
Error indicator light ERR (red)		ON	Self-diagnosed system errors



If software configuration is not comply with hardware configuration or hardware versions are not identical, ERR will be ON.

2.1.5 Communication Interface

There is a 9-pin D standard RS232 serial communication interface (hole type) on the left of the CPU module, and also a 9-pin D standard RS485 serial communication interface (hole type) on LM3108/LM3109. Customer can connect PLC with COM port of PC by RS232 communication interface and programming cable to realize program download and on-line debugging. RS485 communication interface is used to the communication between PLC and other field devices.

Table 2.1.4 CPU Module Communication Parameters

Item	Parameters
Interface quantity	1 / 2
Physical interface	RS232 (non-isolation) / RS485 (non-isolation)
Communication speed	Typical 38400bps
Communication protocol	Proprietary protocol / MODBUS RTU / Free protocol

2.2 8-channel DI/6-channel DO CPU Module LM3104

2.2.1 Technical Specifications

LM3104	
Local I/Os	DI 8 × 24V DC ; DO 6 × Transistor output
Maximum expansion modules	2 expansion modules (no DP slave interface module and Ethernet interface module)
High-speed counters	3 monophase counters, 100KHz / 2 biphasic counters, 100KHz
High-speed output	1 point, 20KHz
Pulse catch	2 points
Interruption inputs	2 points
Analog potentiometers	2, setting value range: 0~255
Customer program memory	28K bytes
Retain area	No

Password	Yes	
Real-time clock	No	
Timers	No quantity limit (minimum unit is 1ms)	
Counters	No quantity limit (maximum count range: 16bits)	
Basic instructions	340	
Expansion instructions	47	
Calculation speed	0.37 μ s (Single Boolean instruction)	
Power supply specifications		
Power supply	Power supply voltage	24V DC
	Allowed range	21~27V DC
	Current consumption (Max.)	1300mA
Output power supply	Output voltage	24V DC
	Allowed range	22.8~25.2V DC

Output current	+24V DC (to expansion bus)	300mA
	+24V DC (Output power supply)	300mA
	+5V DC (to expansion bus)	800mA
Short circuit protection	400mA, 24V DC output	

Communication features	
Communication interface	1 RS232 port (non-isolation)
Communication protocol	Proprietary/Modbus protocol/Free protocol

Input features	
Input type	Sink/Source
Input rated voltage	24V DC
Allowed range	0~30V DC
Logic 1 signal	15~30V DC, allowed minimum current 3mA
Logic 0 signal	0~5V DC, allowed maximum current 1mA
Input delay time	<0.6ms (Rated input voltage)
Isolation mode	Optical-coupler isolation
Isolation group	1 group
Isolation endurance voltage	1500V AC

Output features	
Output type	Transistor
Output voltage	24V DC
Allowed range	20.4~28.8V DC
Transistor conduction voltage drop	< 0.5V (when current is 1A, output logic "1")
Contact impedance	< 0.2 Ω
Logic "1" single point maximum output current	1A
Logic "0" maximum sink current	1mA

Common end total output current	< 4A
Isolation	Optical-coupler isolation
Isolation group	2 groups
Isolation endurance voltage	1500V AC
Response time (state from “0” to “1”n or from “1” to “0”)	Normal output < 1ms, High-speed pulse output < 10μs
Short circuit protection	Externally provided
Physical features	
Dimensions	125mm(L) × 90mm(W) × 70mm(H)
Weight	310g
Working temperature	0~55°C
Storage temperature	-40~+70°C
Relative humidity	5%~95% (no condensation)

2.2.2 LM3104 Terminal Definition and Wiring

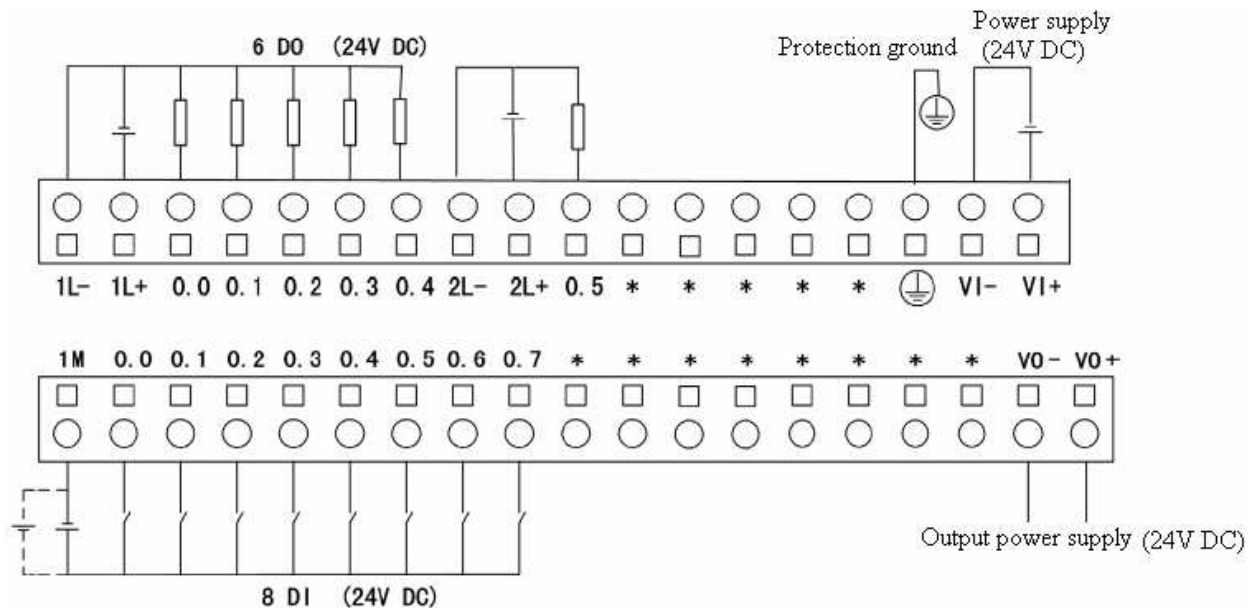



Table 2.2.1 LM3104 Terminals Definition and Wiring Diagram

- **LM3104 terminals definition and wiring instruction**
 - ◇ IM is common terminal of DI, connect to 24VDC +/- terminal corresponding to source/sink DI.
 - ◇ DO 1L+/2L+ and 1L-/2L- connect to load drive power supply 24VDC + and – terminals.
 - ◇ * means that no physical wiring.

● **LM3104 terminal marks and definition**

Upper Terminals	Description	Lower Terminals	Description
1L-	Load drive power supply GND	1M	DI common terminal
1L+	Load drive power supply +24VDC	I0.0	Normal input/High-speed counting input terminal
Q0.0	Normal output terminal	I0.1	Normal input/High-speed counting input control terminal
Q0.1	Normal output terminal	I0.2	Normal input/High-speed counting input terminal
Q0.2	Normal output terminal	I0.3	Normal input/High-speed counting input control terminal
Q0.3	Normal output/High-speed pulse output terminal	I0.4	Normal input/Normal counting input terminal
Q0.4	Normal output terminal	I0.5	Normal input/Normal counting input control terminal
2L-	Load drive power supply -24VDC	I0.6	Normal input/High-speed counting input/External interruption input/Pulse catch input terminal
2L+	Load drive power supply +24VDC	I0.7	Normal input/External interruption input/Pulse catch input terminal
Q0.5	Normal output terminal	*	-
*		*	-
*		*	-
*		*	-
*		*	-
*		*	-
	Protection ground	*	-
VI-	Power supply -24VDC terminal	*	-
VI+	Power supply +24VDC terminal	VO-	Output power supply -24VDC terminal
		VO+	Output power supply +24VDC terminal

2.2.3 LM3104 Communication Function

The standard RS232 serial communication interface, integrated on the CPU module, is for connecting the PC to the PLC with programming cable to program download and on-line debugging.

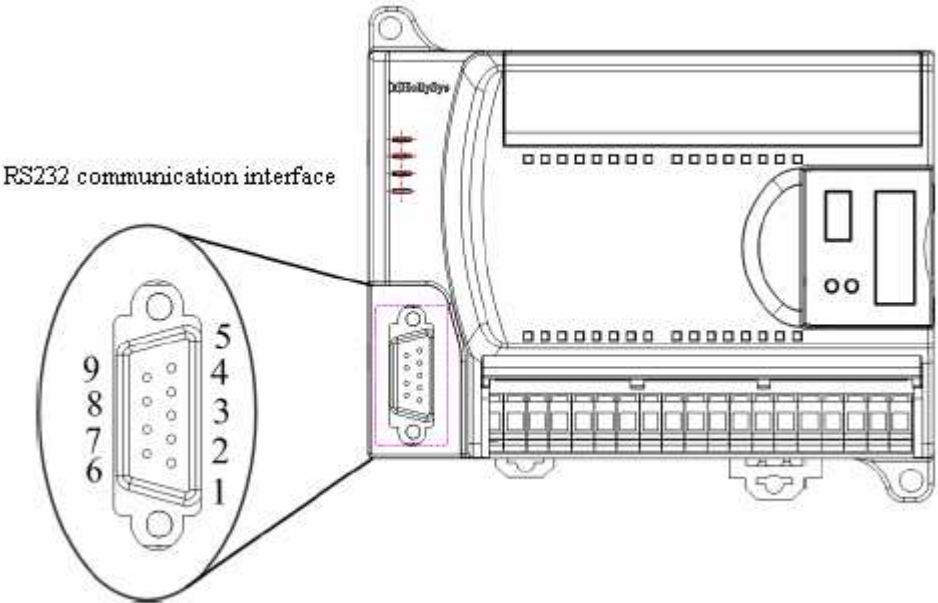

Figure 2.2.2 LM3104 Communication Interface

Table 2.2.1 RS232 Connector Pins Definition

Pin Number	Definition	Pin Number	Definition
1	-	6	-
2	RXD	7	-
3	TXD	8	-
4	-	9	-
5	GND		

2.2.4 LM3104 Equivalent Circuit

◇ Input channel (DI) equivalent circuit shown in Figure 2.2.3.

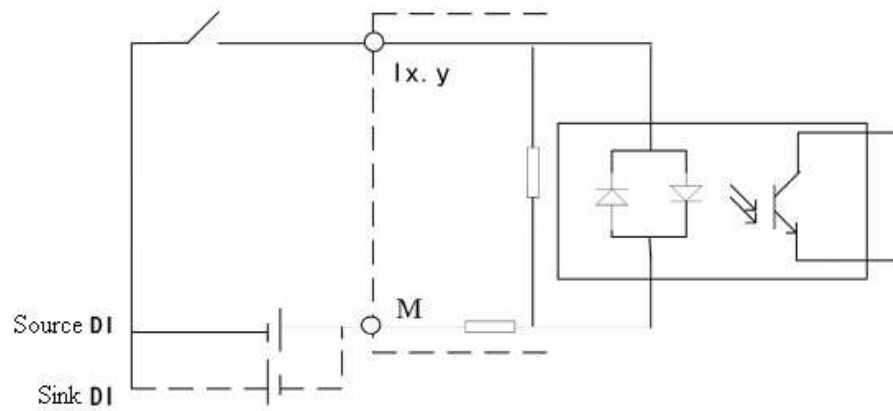

Figure 2.2.3 LM3104 Input Channel Equivalent Circuit

◇ Output channel (DO) equivalent circuit shown in Figure 2.2.4.

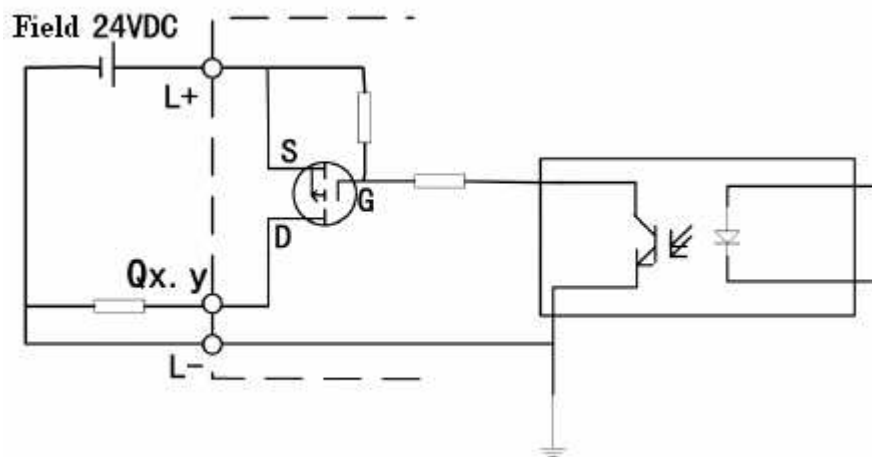

Figure 2.2.4 LM3104 Output Channel Equivalent Circuit

2.2.5 LM3104 Software Configuration

Figure 2.2.5 shows the LM3104 “PLC Configuration” in PowerPro.

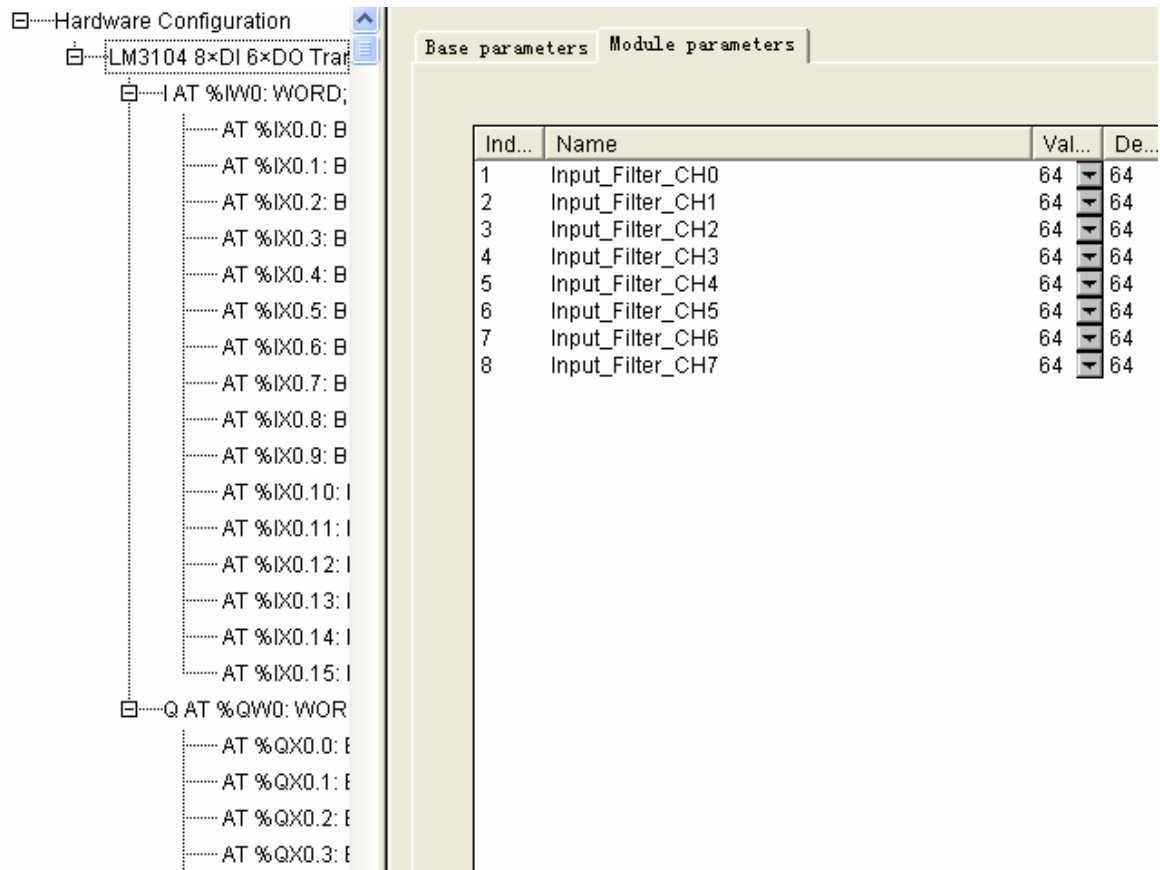

Figure 2.2.5 LM3104 Software Configuration

Input_Filter_CH0 means that the filter parameter of LM3104 first input channel I0.0. There are eight optional filter parameters such as NO, 2, 4, 8, 16, 32, 64 and 128. NO means no filter; 2/4/8/16/32/64/128 means input signal is 1 in 2/4/8/16/32/64/128 continuous PLC scan periods, otherwise input signal is 0. Filter parameter value by default is 64.



Input/output has 16bits (one word) as shown in software configuration. LM3104 actually only uses IX0.0~IX0.7 and QX0.0~QX0.5, other cannels are dull.

2.3 8-channel DI/6-channel DO CPU Module LM3105

2.3.1 Technology Specifications

LM3105		
Local I/Os	DI 8 × 24V DC ; DO 6 × Relay output	
Expandable I/O	2 modules (no LM3401 and LM3403)	
High-speed counter	3 monophase counters, 100KHz / 2 biphasse counters, 100KHz	
High-speed output	No	
Pulse catch	2 points	
Interruption inputs	2 points	
Analog potentiometers	2, value setting range: 0~255	
Customer program memory	28K bytes	
Retain area	No	
Password protection	Yes	
Real-time clock	No	
Timers	No quantity limit (minimum unit is 1ms)	
Counters	No quantity limit (maximum count range: 16bits)	
Basic instructions	340	
Expansion instructions	47	
Calculation speed	0.37μs (Single Boolean instruction)	
Power Specifications		
Power supply	Power supply voltage	24V AC@50Hz
	Allowed range	187~242V AC@50Hz
	Current consumption (MAX)	120mA
Output power supply	Output voltage	24V DC
	Allowed range	22.8V DC~25.2V DC
Output current	+24V DC (To expansion bus)	260mA
	+24V DC (Output power supply)	200mA
	+5V DC (To expansion bus)	800mA
Short circuit protection	400mA, 24V DC output	
Communication features		
Communication interface	1 RS232 port (non-isolation)	
Communication protocol	Proprietary/MODBUS RTU/Free protocol	

Input features	
Input type	Source/Sink
Input voltage rating	24V DC
Allowed range	0V DC~30V DC
Logic 1 signal	15~30V DC, allowed minimum current 3mA
Logic 0 signal	0~5V DC, allowed maximum current 1mA
Input delay time	<0.6ms (Rated input voltage)
Isolation mode	Optical-coupler isolation
Isolation group	1 group
Isolation voltage endurance capability	1500V AC
Output Features	
Output type	Relay
Output voltage	24VDC/24~230VAC
Allowed range	5~30VDC/5~250VAC
Total common end output current	<10A
Output contact capacity	2A, resistance load
Minimum load	10mA (contact voltage is 5VAC/5VDC)
Over-current protection	No
Contact impedance	<0.2Ω
Isolation groups	2 groups
Isolation voltage between coil and contact point	3000VAC, 1min, sink current 1mA
Isolation voltage between contact points	750VAC, 1min, sink current 1mA
Isolation resistance (minimum)	100MΩ (when 500VDC) between contact point/coil and contact point
Contact point switch delay time	<10ms
Contact point switch frequency (maximum)	1Hz
Relay mechanism service life	No load : above 10,000,000 times Rated resistance 2A load : above 100,000 times
Physical features	
Dimensions	125mm(L) × 90mm(W) × 70mm(H)
Weight	310g
Working temperature	0~55°C
Storage temperature	-40~+70°C
Relative humidity	5%~95% (no condensation)

2.3.2 LM3105 Terminals Definition and Wiring

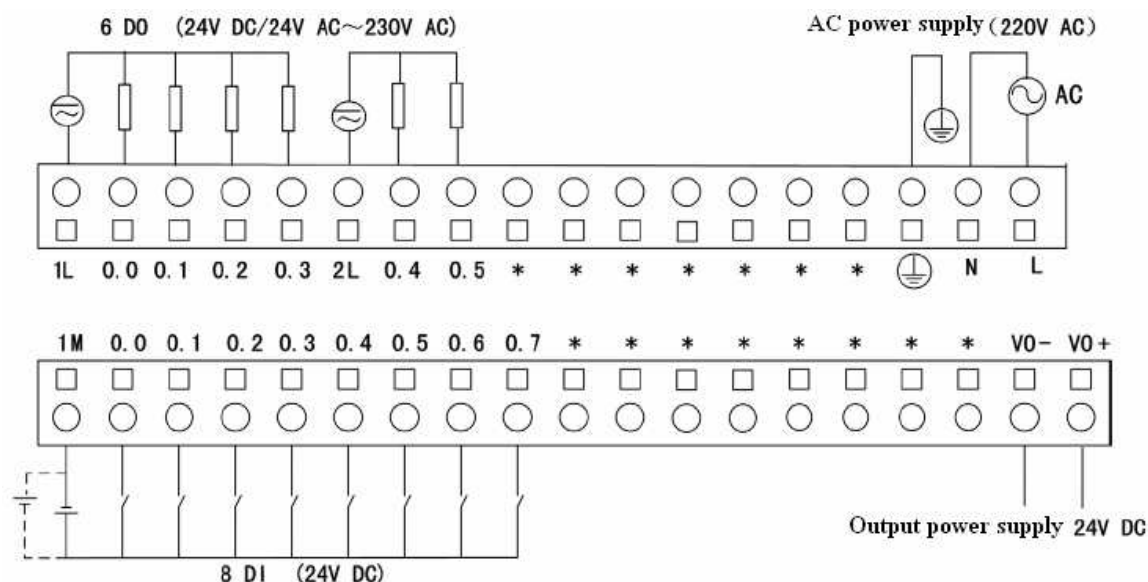

Table 2.3.1 LM3105 Terminals Definition and Wiring Diagram

- LM3105 terminals definition and wiring instruction
 - ◇ IM is common terminal of DI, connects to transducer power supply 24VDC +/- terminal corresponding to source/sink DI.
 - ◇ DO 1L+ /2L+ and 1L- /2L- connect to load drive power supply terminals; load drive power supply can be DC or AC.
 - ◇ * means that no physical wiring.



PLC input power supply wiring must be done under all power-off . Pulling/drawing PLC power supply lines is not allowed when PLC power-on.

- LM3105 terminals marks and definition

Upper Terminals	Description	Lower Terminals	Description
1L	Output common terminal	1M	Input common terminal
Q0.0	Normal output terminal	I0.0	Normal input/High-speed counting input terminal
Q0.1	Normal output terminal	I0.1	Normal input/High-speed counting input control terminal
Q0.2	Normal output terminal	I0.2	Normal input/High-speed counting input

			terminal
Q0.3	Normal output/High-speed pulse output terminal	I0.3	Normal input/High-speed counting input control terminal
2L	Output common terminal	I0.4	Normal input/Normal counting input terminal
Q0.4	Normal output terminal	I0.5	Normal input/Normal counting input control terminal
Q0.5	Normal output terminal	I0.6	Normal input/High-speed counting input/External interruption input/Pulse catch input terminal
*	-	I0.7	Normal input/External interruption input/Pulse catch input terminal
*	-	*	-
*	-	*	-
*	-	*	-
*	-	*	-
*	-	*	-
*	-	*	-
	Protection ground	*	-
N	Neutral	*	-
L	Line	VO-	-24VDC output power supply terminal
		VO+	+24VDC output power supply terminal

2.3.3 LM3105 Communication Function

LM3105 RS232 port pins definition is the same with LM3104; please see the Table 2-2-1.

2.3.4 LM3105 Equivalent Circuit

- ◇ LM3105 Input channel (DI) equivalent circuit is same with LM3104, please see the Figure 2.2.3.
- ◇ LM3105 output channel (DO) equivalent circuit shown in Figure 2.3.2.

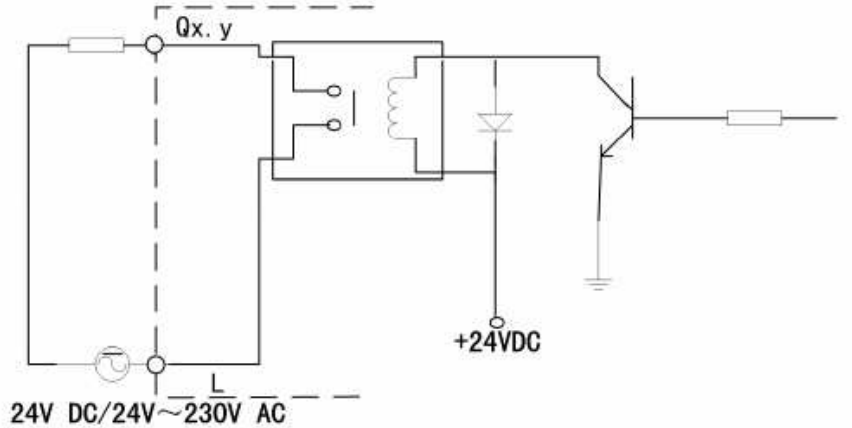

Figure 2.3.2 LM3105 Output Channel Equivalent Circuit

2.3.5 LM3105 Software Configuration

LM3105 software configuration is similar with LM3104; please see the section 2.2.5.

2.4 14-channel DI/10-channel DO CPU Module LM3106

2.4.1 Technical Specifications

LM3106		
Local I/Os	DI 14 × 24V DC ; DO 10 × Transistor output	
Maximum expansion modules	4 expansion modules	
High-speed counters	3 monophas counters, 100KHz / 2 biphas counters, 100KHz	
High-speed output	2 points, 20KHz	
Pulse catch	4 points	
Interruption inputs	4 points	
Analog potentiometers	2, setting value range: 0~255	
Customer program memory	120K bytes	
Retaining area	6K bytes	
Password	Yes	
Real-time clock	Built-in	
Timers	No quantity limit (minimum unit is 1ms)	
Counters	No quantity limit (maximum count range: 16bits)	
Basic instructions	340	
Expansion instructions	47	
Calculation speed	0.37μs (Single Boolean instruction)	
Power supply specifications		
Power supply	Power supply voltage	24V DC
	Allowed range	21~27V DC
	Current consumption (MAX)	1300mA
Output power supply	Output voltage	24V DC
	Allowed range	22.8~25.2V DC
Current output	+24V DC (to expansion bus)	300mA
	+24V DC (Output power supply)	300mA
	+5V DC (to expansion bus)	800mA
Short circuit protection	400mA, 24V DC output	
Communication features		
Communication interface	1 RS232 port (non-isolation)	
Communication protocol	Proprietary/Modbus RTU protocol/Free protocol	
Input features		
Input type	Sink/Source	
Input rated voltage	24V DC	
Allowed range	0~30V DC	
Logic 1 signal	15~30V DC, allowed minimum current 3mA	

Logic 0 signal	0~5V DC, allowed maximum current 1mA
Input delay time	<0.6ms (Rated input voltage)
Isolation mode	Optical-coupler isolation
Isolation groups	2 groups
Isolation voltage endurance capability	1500V AC
Output features	
Output type	Transistor
Output voltage	24V DC
Allowed range	20.4~28.8V DC
Transistor conduction voltage drop	< 0.5V (when current is 1A, output logic “1”)
Contact impedance	< 0.2Ω
Logic “1” single point maximum output current	1A
Logic “0” maximum sink current	1mA
Common end total output current	< 4A
Isolation mode	Optical-coupler isolation
Isolation group	2 groups
Isolation voltage endurance capability	1500V AC
Response time (state from “0” to “1”n or from “1” to “0”)	Normal output < 1ms, High-speed pulse output < 10μs
Short circuit protection	Externally provided
Physical features	
Dimensions	125mm(L) × 90mm(W) × 70mm(H)
Weight	310g
Working temperature	0~55°C
Storage temperature	-40~+70°C
Relative humidity	5%~95% (no condensation)

2.4.2 LM3106 Terminals Definition and Wiring

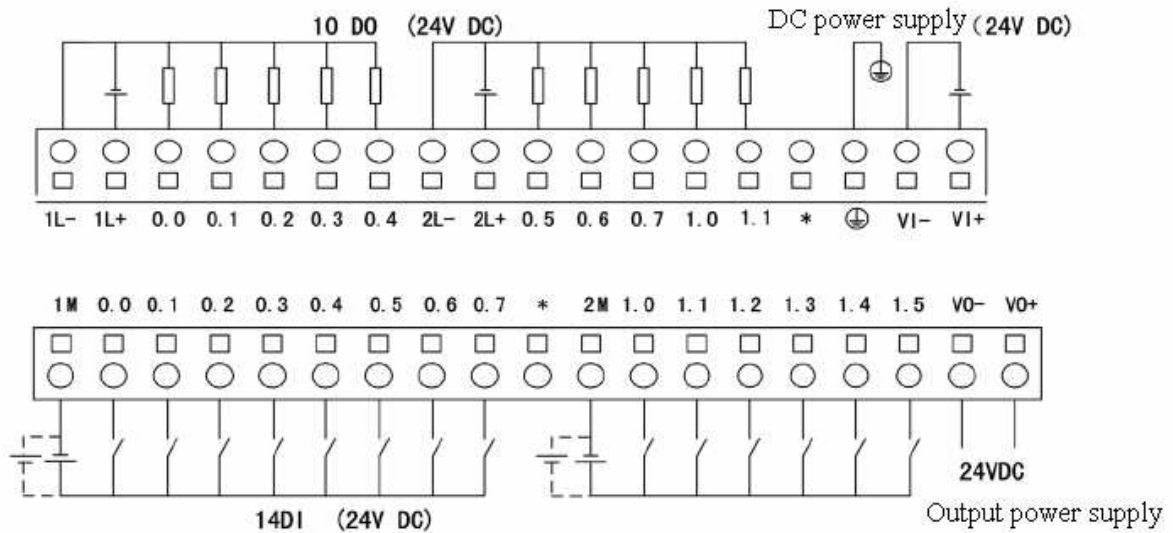

Table 2.4.1 LM3106 Terminals Definition and Wiring Diagram

- **LM3106 terminals definition and wiring instruction**
 - ◇ IM and 2M terminals are common terminals of DI; connect to transducer power supply 24VDC +/- terminal corresponding to source/sink DI.
 - ◇ DO 1L+/2L+ and 1L-/2L- connect to load drive power supply 24VDC + and - terminals respectively.
 - ◇ * means that no physical wiring.
 - ◇ Figure 2.4.2 and Figure 2.4.3 show two examples of the connection between LM3106 high-speed output and motor. 1.6KΩ resistance is used to driver rated current value between 10 and 20mA. The connection method shown in Figure 2.4.2 is recommend as it has better anti-jamming ability. The connection method shown in Figure 2.4.3 is the same with normal output wiring, and adopted without high precision requirement.

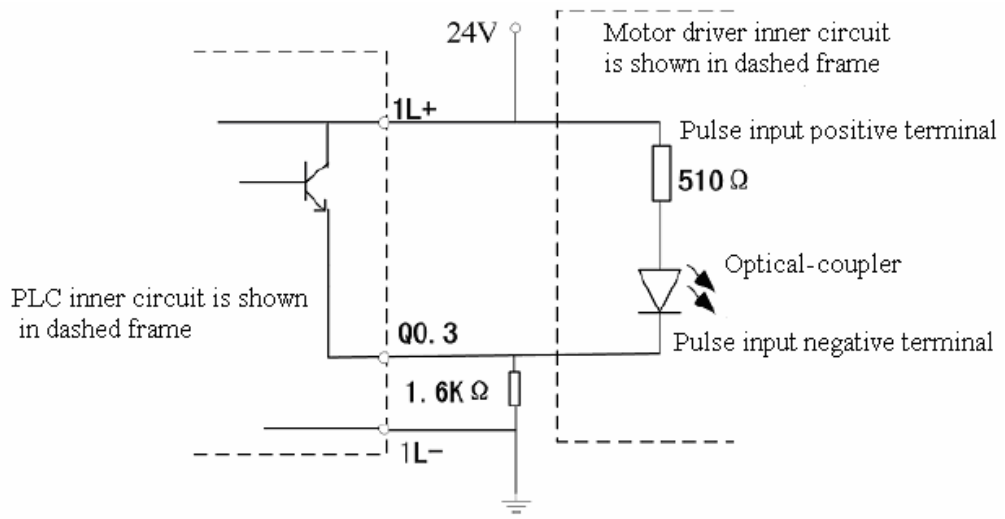

Figure 2.4.2 The Connection between LM3106 High-speed Output and Motor Example1 (same connection method to Q1.1)

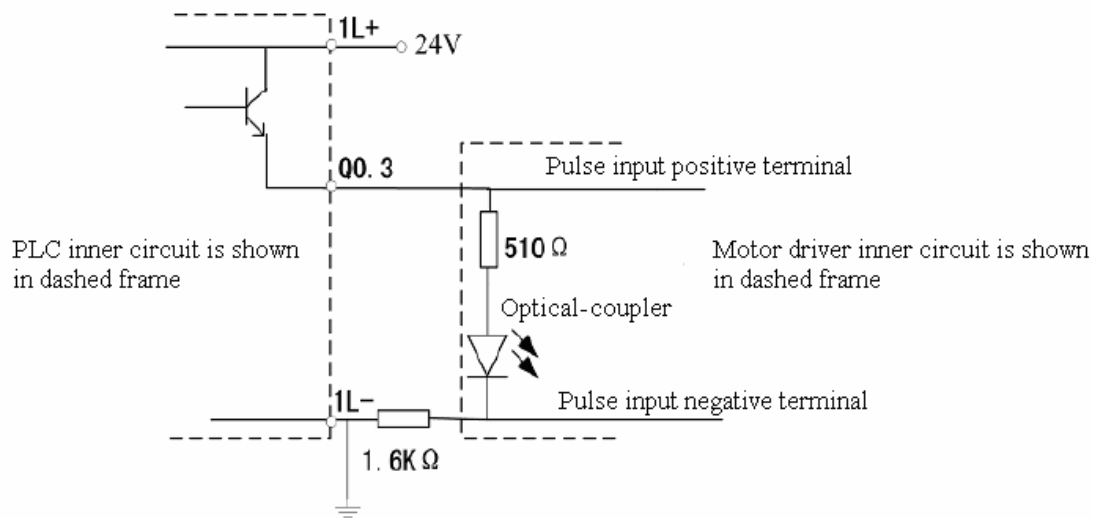



Figure 2.4.3 The Connection between LM3106 High-speed Output and Motor Example2 (same connection method to Q1.1)

i External resistance is used to the motor driver with 5V plus voltage. The motor drivers with different pulse voltage connect with different external resistances, please reference the motor driver manual.

- **LM3106 terminals marks and definition**

Upper Terminals	Description	Lower Terminals	Description
1L-	Load drive power supply GND	1M	DI common terminal
1L+	Load drive power supply +24VDC	I0.0	Normal input/High-speed counting input terminal
Q0.0	Normal output terminal	I0.1	Normal input/High-speed counting input control terminal
Q0.1	Normal output terminal	I0.2	Normal input/High-speed counting input terminal
Q0.2	Normal output terminal	I0.3	Normal input/High-speed counting input control terminal
Q0.3	Normal output/High-speed pulse output terminal	I0.4	Normal input/Normal counting input terminal
Q0.4	Normal output terminal	I0.5	Normal input/Normal counting input control terminal
2L-	Load drive power supply GND	I0.6	Normal input/High-speed counting input/External interruption input/Pulse catch input terminal
2L+	Load drive power supply +24VDC	I0.7	Normal input/External interruption input/Pulse catch input terminal
Q0.5	Normal output terminal	*	-
Q0.6	Normal output terminal	2M	DI common terminal
Q0.7	Normal output terminal	I1.0	Normal input/External interruption input/Pulse catch input terminal
Q1.0	Normal output terminal	I1.1	Normal input/External interruption input/Pulse catch input terminal
Q1.1	Normal output/High-speed pulse output terminal	I1.2	Normal input terminal
*	-	I1.3	Normal input terminal
	Protection ground	I1.4	Normal input terminal
VI-	24VDC power supply negative terminal	I1.5	Normal input terminal
VI+	24VDC power supply positive terminal	VO-	-24VDC output power supply terminal
		VO+	+24VDC output power supply terminal

2.4.3 LM3106 Communication Function

LM3106 RS232 port pins definition is the same with LM3104. Please see the Table 2-2-1.

2.3.4 LM3106 Equivalent Circuit

◇ LM3106 DI equivalent circuit is same with LM3104; please see the Figure 2.2.3.

◇ LM3105 DO equivalent circuit is same with LM3104; please see the Figure 2.2.4.

2.3.5 LM3106 Software Configuration

LM3106 software configuration is similar with LM3104; please see the section 2.2.5.

2.5 14-channel DI/10-channel DO CPU Module LM3106A

2.5.1 Technical Specifications

LM3106A		
Local I/O	DI 14 × 24V DC ; DO 10 × Transistor output	
Maximum expansion modules	4 expansion modules	
High-speed counters	3 monophase counters, 100KHz / 2 biphasic counters, 100KHz	
High-speed outputs	2 points as PWM (100KHz) or PTO (50KHz)	
Pulse catch	4 points	
Interruption inputs	4 points	
Analog potentiometers	2, setting value range: 0~255	
Customer program memory	120K bytes	
Retention area	6K bytes	
Password	Yes	
Real-time clock	Built-in	
Timers	No quantity limit (minimum unit is 1ms)	
Counters	No quantity limit (maximum count range: 16 bits)	
Basic instructions	340	
Expansion instructions	47	
Compute speed	0.37μs (Single Boolean instruction)	
Power supply specifications		
Input power supply	Power supply voltage	24V DC
	Allowed range	21~27V DC
	Current consumption (MAX)	1300mA
Output power supply	Output voltage	24V DC
	Allowed range	22.8~25.2V DC
Current output	+24V DC (to expansion bus)	300mA
	+24V DC (Output power supply)	300mA
	+5V DC (to expansion bus)	800mA
Short circuit protection	400mA, 24V DC output	
Communication features		
Communication interface	1 RS232 port (non-isolation)	
Communication protocol	Proprietary/Modbus RTU protocol/Free protocol	
Input features		
Input type	Sink/Source	
Input rated voltage	24VDC	
Allowed range	0~30VDC	
Logic 1 signal	15~30VDC, allowed minimum current 3mA	

Logic 0 signal	0~5V DC, allowed maximum current 1mA
Input delay time	<0.6ms (Rated input voltage)
Isolation mode	Optical-coupler isolation
Isolation groups	2 groups
Isolation endurance voltage	1500V AC
Output features	
Output type	Transistor
Output voltage	5~24V DC
Allowed range	4.5~28.8V DC
Transistor conduction voltage drop	< 0.5V (when load voltage is +5V)
Contact impedance	< 0.2Ω
Logic “1” single point maximum output current	0.2A
Logic “0” maximum sink current	0.1mA
Common end total output current	< 0.5A
Isolation mode	Optical-coupler isolation
Isolation groups	2 groups
Isolation endurance voltage	1500V AC
Short circuit protection	Externally provided
Response time (state from “0” to “1”n or from “1” to “0”)	Normal output (above 15mA): OFF→ON:<0.1ms ON→OFF:< 1ms High-speed pulse output (above 15mA): OFF→ON:<0.5μs ON→OFF:< 1.5μs
Physical features	
Dimensions	125mm(L) × 90mm(W) × 70mm(H)
Weight	310g
Working temperature	0~55°C
Storage temperature	-40~+70°C
Relative humidity	5%~95% (no condensation)

2.5.2 LM3106A Terminals Definition and Wiring

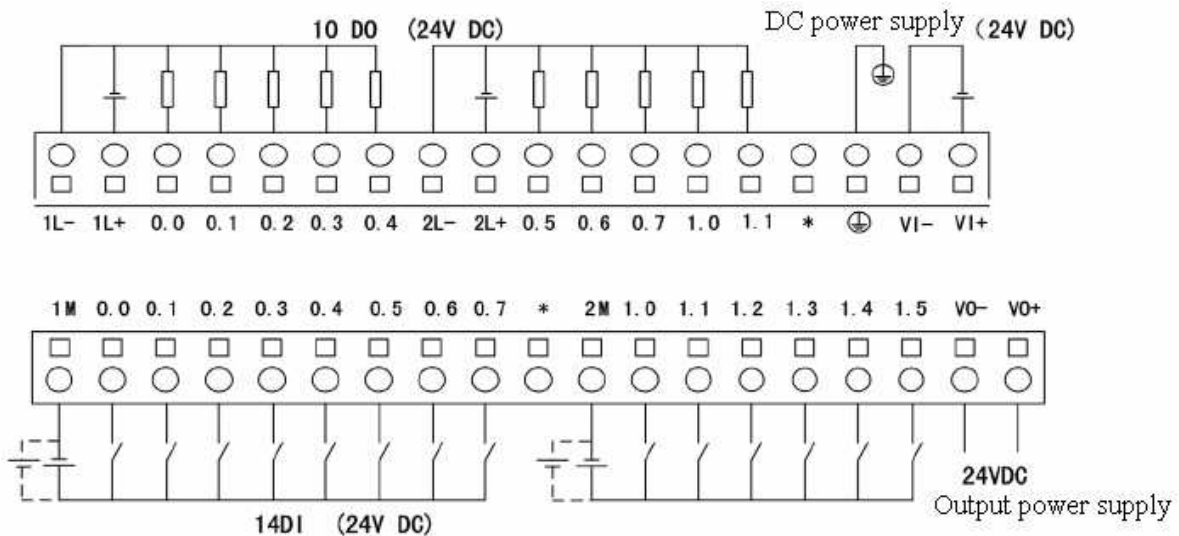

Table 2.5.1 LM3106A Terminals Definition and Wiring Diagram

- **LM3106 terminals definition and wiring instruction**
 - ◇ IM/2M is common terminal of DI, connect to transducer power supply 24VDC +/- terminal corresponding to source/sink DI.
 - ◇ DO 1L+/2L+ and 1L-/2L- connect to load drive power supply 5~24VDC + and - terminals respectively.
 - ◇ * means no physical wiring.
 - ◇ Figure 2.5.2 and Figure 2.5.3 show two examples of the connection between LM3106A high-speed output and motor, and L+ connects with 24V and 5V respectively. In figure 2.5.2, L+ connects with 24V. 1.6K Ω resistance is used to the drive rated current value between 10 and 20mA; its resistance value depends on the load (motor driver) current value, and assures that the dynatron current is between 15mA and 100mA when the output dynatron is break-over to supply current channel to the high-speed output. In Figure 2.5.2, when the application program sets Q0.3 value as 1 the dynatron is break-over and does not drive load; when the application program sets Q0.3 value as 0 the dynatron is not break-over and drives load. Figure 2.5.3 is suitable to L+ connects with 5V.

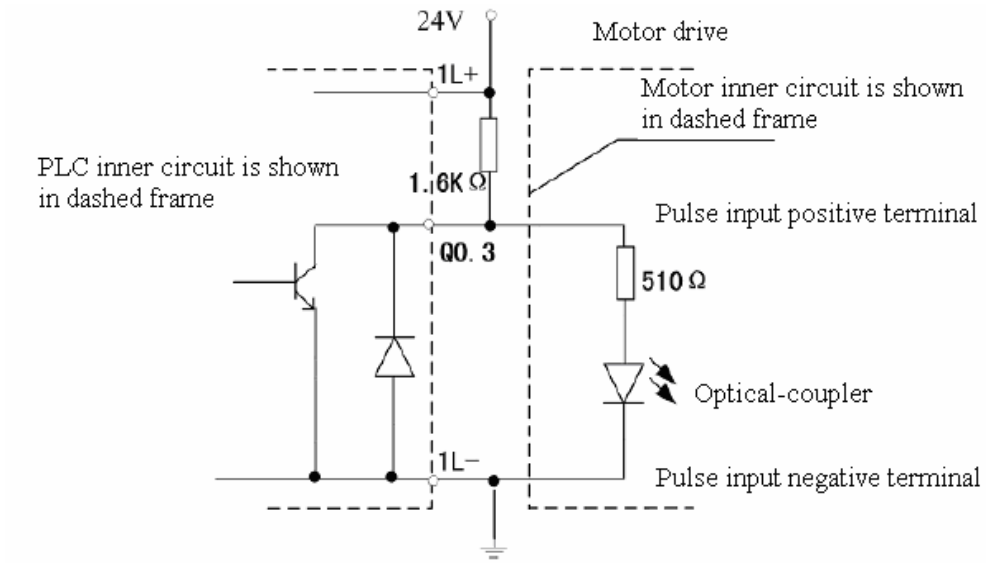

Figure 2.5.2 The Connection between LM3106A High-speed Output and Motor Example1 (same connection method to Q1.1)

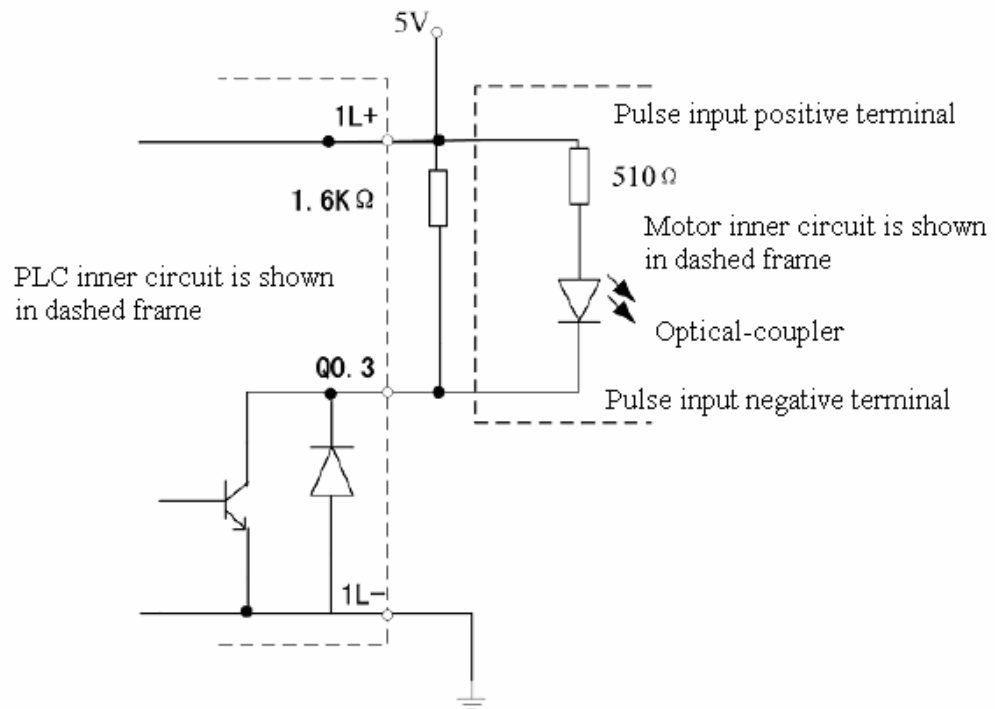



Figure 2.5.3 The Connection between LM3106 High-speed Output and Motor Example2 (same connection method to Q1.1)

● **LM3106A terminals marks and definition**

Upper Terminals	Description	Lower Terminals	Description
1L-	Load drive power supply GND	1M	DI common terminal
1L+	Load drive power supply 5~24VDC	I0.0	Normal input/High-speed counting input terminal
Q0.0	Normal output terminal	I0.1	Normal input/High-speed counting input control terminal
Q0.1	Normal output terminal	I0.2	Normal input/High-speed counting input terminal
Q0.2	Normal output terminal	I0.3	Normal input/High-speed counting input control terminal
Q0.3	Normal output/High-speed pulse output terminal	I0.4	Normal input/Normal counting input terminal
Q0.4	Normal output terminal	I0.5	Normal input/Normal counting input control terminal
2L-	Load drive power supply GND	I0.6	Normal input/High-speed counting input/External interruption input/Pulse catch input terminal
2L+	Load drive power supply 5~24VDC	I0.7	Normal input/External interruption input/Pulse catch input terminal
Q0.5	Normal output terminal	*	-
Q0.6	Normal output terminal	2M	External input common terminal
Q0.7	Normal output terminal	I1.0	Normal input/External interruption input/Pulse catch input terminal
Q1.0	Normal output terminal	I1.1	Normal input/External interruption input/Pulse catch input terminal
Q1.1	Normal output/High-speed pulse output terminal	I1.2	Normal input terminal
*	-	I1.3	Normal input terminal
	Protection ground	I1.4	Normal input terminal
VI-	24VDC power supply negative terminal	I1.5	Normal input terminal
VI+	24VDC power supply positive terminal	VO-	Output power supply -24VDC terminal
		VO+	Output power supply +24VDC terminal

2.5.3 LM3106A Communication Function

LM3106A RS232 port pins definition is same with LM3104. Please see the Table 2-2-1.

2.5.4 LM3106A Equivalent Circuit

◇ LM3106A input channel (DI) equivalent circuit is same with LM3104; please see the Figure 2.2.3.

◇ LM3106A output channel (DO) equivalent circuit shown in Figure 2.5.4.

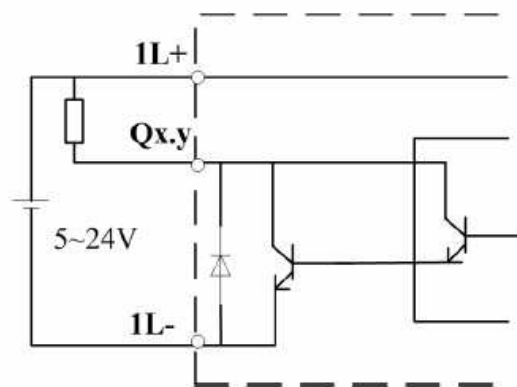

Figure 2.5.4 LM3106A Output Channel Equivalent Circuit

2.5.5 LM3106A Software Configuration

Choose LM3106 as PLC type when doing LM3106A software configuration; the other configurations are similar with LM3104, please see the section 2.2.5.

2.6 8-channel DI/6-channel DO CPU Module LM3107

2.6.1 Technical Specifications

LM3107		
Local I/Os	DI 14 × 24V DC ; DO 10× Relay output	
Maximum expansion modules	4 modules	
High-speed counter	3 monophaser counters, 100KHz / 2 biphaser counters, 100KHz	
High-speed output	No	
Pulse catch	4 points	
Interruption input	4 points	
Analog potentiometer	2, value setting range 0~255	
Customer program memory	120Kbytes	
Retain area	6Kbytes	
Password protection	Yes	
Real-time clock	Built-in	
Timer	No quantity limit (1ms as minimum unit)	
Counter	No quantity limit (Maximum counting range: 16bit)	
Basic instructions	340	
Expansion instructions	47	
Compute speed	0.37μs (Single Boolean instruction)	
Power Specifications		
Input power supply	Power supply voltage	220V AC@50Hz
	Allowed range	187~242V AC@50Hz
	Current consumption (MAX)	120mA
Output power supply	Output voltage	24V DC
	Allowed range	22.8V DC~25.2V DC
Output current	+24V DC (To expansion bus)	260mA
	+24V DC (To Output power supply)	200mA
	+5V DC (To expansion bus)	800mA
Short circuit protection	400mA, 24V DC output	
Communication features		
Communication interface	1 RS-232 (Non-isolation)	
Communication protocol	Proprietary/MODBUS RTU/Free protocol	

Input features	
Input type	Source/Sink
Input voltage rating	24V DC
Allowed range	0V DC~30V DC
Logic 1 signal	15~30V DC, allowed minimum current 3mA
Logic 0 signal	0~5V DC, allowed maximum current 1mA
Input delay time	<0.6ms (Rated input voltage)
Isolation mode	Optical-couple isolation
Isolation group	2 groups
Isolation endurance voltage	1500V AC
Output Features	
Output type	Relay
Output voltage	24VDC/24~230VAC
Allowed range	5~30VDC/5~250VAC
Common end output current total	<10A
Output contact capacity	2A, resistance load
Minimum load	10mA (contact voltage is 5VAC/5VDC)
Over-current protection	No
On state impedance	<0.2Ω
Isolation groups	2 groups
Isolation voltage between coil and contact	3000VAC, 1min, sink current 1mA
Isolation voltage between contacts	750VAC, 1min, sink current 1mA
Isolation resistance (minimum)	100MΩ (when 500VDC) between contacts/coil and contact
Contact switch delay time	<10ms
Contact switch frequency (maximum)	1Hz
Relay mechanism service life	No load : above 10,000,000 times Rated resistance 2A load : above 100,000 times
Physical features	
Dimensions	125mm(L) × 90mm(W) × 70mm(H)
Weight	380g
Working temperature	0~55°C
Storage temperature	-40~+70°C
Relative humidity	5%~95% (no condensation)

2.6.2 LM3107 Terminals Definition and Wiring

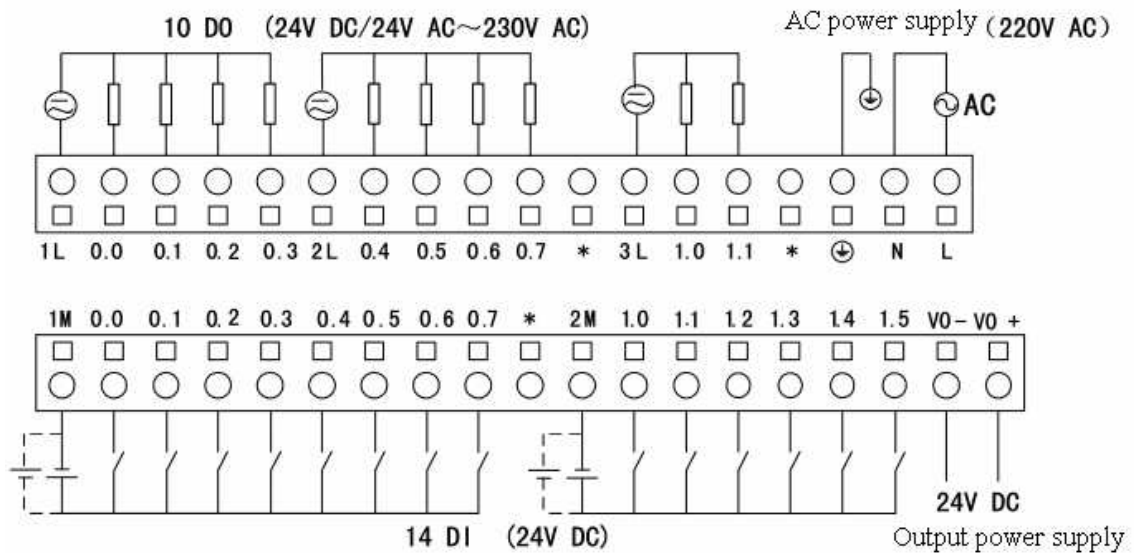

Table 2.6.1 LM3107 Terminals Definition and Wiring Diagram

- **LM3107 terminals definition and wiring instruction**

- ◇ IM/2M is common terminal of DI, connect to transducer power supply 24VDC +/- terminal corresponding to source/sink DI.
- ◇ DO 1L /2L/3L is load drive power supply terminal; load driver power supply can be DC or AC.
- ◇ * means no physical wiring.



PLC input power supply wiring must be done under all power-off . Pulling/drawing PLC power supply lines is not allowed when PLC power-on.

- **LM3107 Terminals Marks and Definition**

Upper Terminals	Description	Lower Terminals	Description
1L	Output common terminal	1M	Input common terminal
Q0.0	Normal output terminal	I0.0	Normal input/High-speed counting input terminal
Q0.1	Normal output terminal	I0.1	Normal input/High-speed counting input control terminal
Q0.2	Normal output terminal	I0.2	Normal input/High-speed counting input

Q0.3	Normal output terminal	I0.3	terminal Normal input/High-speed counting input control terminal
2L	Output common terminal	I0.4	Normal input/Normal counting input terminal
Q0.4	Normal output terminal	I0.5	Normal input/Normal counting input control terminal
Q0.5	Normal output terminal	I0.6	Normal input/High-speed counting input/External interruption input/Pulse catch input terminal
Q0.6	Normal output terminal	I0.7	Normal input/External interruption input/Pulse catch input terminal
Q0.7	Normal output terminal	*	-
*	-	2M	External input common terminal
3L	Output common terminal	I1.0	Normal input/External interruption input/Pulse catch input terminal
Q0.0	Normal output terminal	I1.1	Normal input/External interruption input/Pulse catch input terminal
Q0.1	Normal output terminal	I1.2	Normal input terminal
*	-	I1.3	Normal input terminal
	Protection ground	I1.4	Normal input terminal
N	Line	I1.5	Normal input terminal
L	Neutral	VO-	-24VDC output power supply terminal
		VO+	+24VDC output power supply terminal

2.3.3 LM3107 Communication Function

LM3107 RS232 port pins definition is same with LM3104. Please see the Table 2-2-1.

2.6.4 LM3107 Equivalent Circuit

◇ LM3107 Input channel (DI) equivalent circuit is same with LM3104; please see the Figure 2.2.3.

◇ LM3105 output channel (DO) equivalent circuit is same with LM3105; please see the Figure 2.3.2.

2.6.5 LM3107 Software Configuration

LM3107 software configuration is similar with LM3104; please see the section 2.2.5.

2.7 24 Channel DI/16 Channel DO CPU Module LM3108

2.7.1 Specifications

LM3108		
Local I/Os	DI 24 × 24V DC ; DO 16 × Transistor output	
Maximum expansion modules	7	
High-speed counters	3 monophase counters, 100KHz / 2 biphasic counters, 100KHz	
High-speed outputs	2 points 20KHz	
Pulse catch	4 points	
Interrupt inputs	4 points	
Analog potentiometers	2, value setting range: 0~255	
Customer program memory	120Kbyte	
Retain area	6Kbyte	
Password protection	Yes	
Real-time clock	Built-in	
Timers	No quantity limit (1ms as minimum unit)	
Counters	No quantity limit (Maximum counting range: 16bit)	
Basic instructions	340	
Expansion instructions	47	
Calculation speed	0.37μs (Single Boolean instruction)	
Power Specifications		
Input power	Power voltage	24VDC
	Allowed range	21~27VDC
	Current consumption(MAX)	1500mA
Output power	Output voltage	24V DC
	Allowed range	22.8~25.2V DC
External output current	+24VDC (to expansion bus)	400mA
	+24VDC (output power supply)	400mA
	+5VDC (to expansion bus)	1500mA
Short circuit protection	900mA, 24VDC output	
Communication Features		
Communication interface	1 RS232 port (non-isolation), 1 RS485 port (non-isolation)	

Communication protocol	Proprietary protocol(only RS232)/MODBUS RTU protocol/Free protocol)
Input Features	
Input type	Sink/Source
Input voltage rated value	24V DC
Allowed range	0~30V DC
Logic 1 signal	15~30V DC allowed minimum current 3 mA
Logic 0 signal	0~5V DC allowed maximum current 1 mA
Input delay time	<0.6ms (Rated input voltage)
Isolation	Optical-coupler isolation
Isolation groups	3 groups
Isolation endurance voltage	1500VAC
Output Features	
Output type	Transistor
Output voltage	24V DC
Allowed range	20.4V DC~28.8V DC
Transistor Conducting voltage drop	<0.5V (output logic “1”, current 1A)
Contact impedance	<0.2Ω
Logic”1” single output maximum current	1A
Logic”0” maximum leaking current	1mA
Common end output current total	<4A
Isolation	Optical-coupler isolation
Isolation groups	2 groups
Isolation endurance voltage	1500VAC
Response time (status “0” to “1” or “1” to “0”)	Common output<1ms, High-speed pulse output<10μs
Short circuit protection	External supply
Physical Features	
Dimensions	200mm(L)×90mm(W)×70mm(H)
Weight	470g
Working temperature	0~+55℃
Storage temperature	-40~+70℃
Relative humidity	5%~95% (Non-condensing)

2.7.2 LM3108 Terminal Definition & Wiring

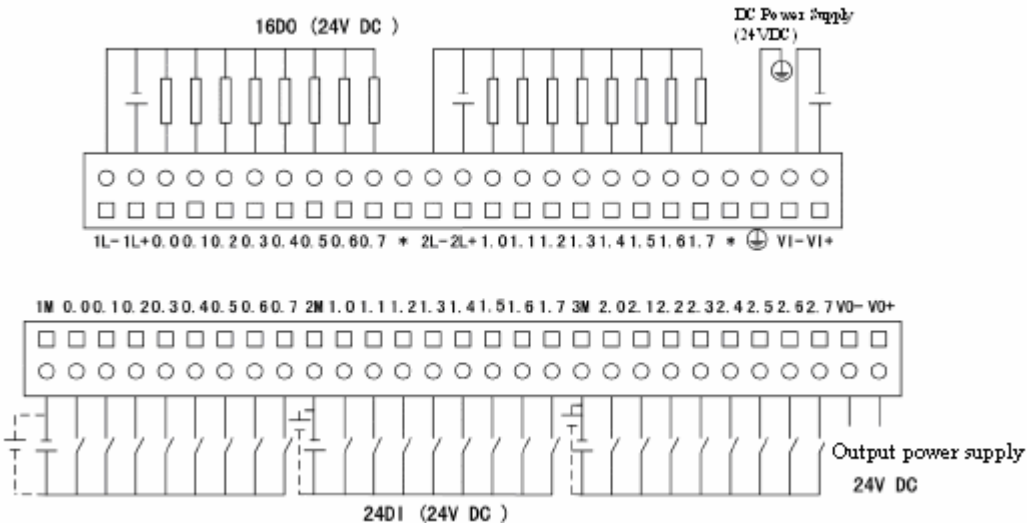

Figure 2-7-1 LM3108 Terminal Definition & Wiring

- ◇ LM3108 terminal definition and wiring description
 - 1M, 2M and 3M are common terminals of DI, connect to 24VDC +/- terminal corresponding to source/sink DI.
 - DO 1L+/2L+ and 1L-/2L- connect to load drive power supply 24VDC + and – terminals.
 - * means no physical wiring.

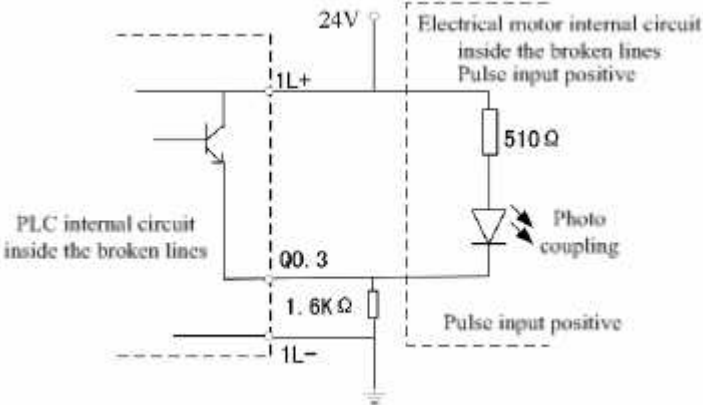

Figure 2-7-2 LM3108 High-Speed Output & Motor Wiring Example 1 (Q1.1 same wiring)

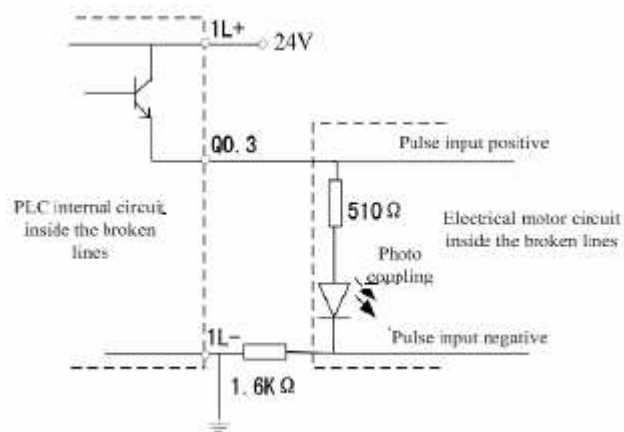



Figure 2-7-3 LM3108 High-Speed Output & Motor Wiring Example 2 (Q1.1 same wiring)

◇ LM3108 Terminal Maker Definition

Upper terminals	Terminal descriptions	Lower terminals	Terminal descriptions
1L-	Load drive power supply GND	1M	DI common terminal
1L+	Load drive power supply +24VDC	I0.0	Normal input/High-speed counting input terminal
Q0.0	Normal output terminal	I0.1	Normal input/High-speed counting input control terminal
Q0.1	Normal output terminal	I0.2	Normal input/High-speed counting input terminal
Q0.2	Normal output terminal	I0.3	Normal input/High-speed counting input control terminal
Q0.3	Normal output/High-speed pulse output terminal	I0.4	Normal input/Normal counting input terminal
Q0.4	Normal output terminal	I0.5	Normal input/Normal counting input control terminal
Q0.5	Normal output terminal	I0.6	Normal input/High-speed counting input/Interruption input/Pulse catch input terminal
Q0.6	Normal output terminal	I0.7	Normal input/Interruption input/Pulse catch input
Q0.7	Normal output terminal	2M	DI common terminal
*	-	I1.0	Normal input/Interruption input/Pulse catch input terminal
2L-	Load drive power supply GND	I1.1	Normal input/Interruption input/Pulse

			catch input terminal
2L+	Load drive power +24VDC	I1.2	Normal input terminal
Q1.0	Normal output terminal	I1.3	Normal input terminal
Q1.1	Normal output/High-speed pulse output terminal	I1.4	Normal input terminal
Q1.2	Normal output terminal	I1.5	Normal input terminal
Q1.3	Normal output terminal	I1.6	Normal input terminal
Q1.4	Normal output terminal	I1.7	Normal input terminal
Q1.5	Normal output terminal	3M	DI common terminal
Q1.6	Normal output terminal	I2.0	Normal input terminal
Q1.7	Normal output terminal	I2.1	Normal input terminal
*	-	I2.2	Normal input terminal
	Ground protection	I2.3	Normal input terminal
VI-	-24VDC Power supply terminal	I2.4	Normal input terminal
VI+	+24VDC Power supply terminal	I2.5	Normal input terminal
		I2.6	Normal input terminal
		I2.7	Normal input terminal
		VO-	-24VDC output power supply terminal
		VO+	+24VDC output power supply terminal

2.7.3 LM3108 Communication Function

A standard RS232 and a RS485 serial communication interface integrated on CPU module. Through RS232 user can connect PLC with PC COM port with programming cable to customer program download and modification. RS485 interface will realize communication between PLC and field devices.



Figure 2-7-4 LM3108 Communication Interface

Table 2-7-1 RS232 port pins definition

pin No.	Definition	pin No.	Definition
1	-	6	-
2	RXD	7	-
3	TXD	8	-
4	-	9	-
5	GND		

Table 2-7-2 RS485 port pins definition

Linker pin No.	Definition	Linker pin No.	Definition
1	-	6	-
2	-	7	-
3	B (RXD/TXD+)	8	A (RXD/TXD-)
4	-	9	-
5	-		

2.7.4 LM3108 Equivalent Circuit

- ◇ Input channel (DI) equivalent circuit is the same as the input channel of LM3104. Please see Figure 2-2-3.
- ◇ Output channel (DO) equivalent circuit is the same as the output channel of LM3104. Please see Figure 2-2-4.

2.7.5 LM3108 Software Configuration

LM3108 software configuration is similar to LM3104; please refer to 2.2.5 section.

2.8 24 Channel DI/16 Channel DO CPU Module LM3109

2.8.1 Specifications

LM3109	
Local I/Os	DI 24 × 24V DC ; DO 16 × Relay output
Maximum expansion modules	7
High-speed counters	3 monophas counters, 100KHz / 2 biphas counters, 100KHz
High-speed output	No

Pulse catch	4 points	
Interruption inputs	4 points	
Analog potentiometers	2, value setting range: 0~255	
Customer program memory	120Kbyte	
Power off Retain area	6Kbyte	
Password protection	Yes	
Real-time clock	Built-in	
Timers	No quantity limit (1ms as minimum unit)	
Counters	No quantity limit (Maximum counting range: 16bit)	
Basic instructions	340	
Expansion instructions	47	
Operation speed	0.37 μ s (Single Boolean instruction)	
Power Specifications		
Input power	Power voltage	220V AC@50Hz
	Allowed range	187~242V AC@50Hz
	Current consumption(MAX)	200mA
Output power	Output voltage	24V DC
	Allowed range	22.8~25.2V DC
External output current	+24V DC (to expansion bus)	320mA
	+24V DC (Output power supply)	400mA
	+5V DC (to expansion bus)	1300mA
Short circuit protection	900mA, 24VDC output	
Communication Features		
Communication interface	RS232 and RS485 (Non-isolating)	
Communication protocol	Proprietary protocol(only RS232)/MODBUS RTU protocol/Free protocol	
Input Features		
Input type	Sink/Source	
Input rated voltage	24V DC	
Allowed range	0~30V DC	
Logic 1 signal	15~30V DC allowed minimum current 3 mA	
Logic 0 signal	0~5V DC allowed maximum current 1 mA	
Input delay time	<0.6ms (Input rated voltage)	
Isolation	Optical-coupler isolation	
Isolation groups	3 groups	

Isolation endurance voltage	1500VAC
Output Features	
Output type	Relay
Output voltage	24V DC or 24~230VAC
Allowed range	5~30V DC or 5~250V AC
Common end output total current	<10A
Output On/Off capacity	2A, Resistance load
Minimum load	10mA (Voltage between contacts 5VAC or 5VDC)
Over current protection	None
On impedance (contact impedance)	<0.2Ω
Isolation groups	4 groups
Isolation voltage between coil and contact	3000VAC, 1 minute, leakage current 1mA
Isolation voltage between contacts	750VAC, 1 minute, leakage current 1mA
Isolation resistance (minimum)	Between contacts or between coil and contact are both 100MΩ (500VDC)
Contact On/Off delay time	<10ms
Contact On/Off frequency (maximum)	1Hz
Relay mechanism service life	No load: over 10,000,000 times Rated resistance 2A load: over 100,000 times
Physical Features	
Dimensions	200mm(L)×90mm(W)×70mm(H)
Weight	550g
Working temperature	0~+55°C
Storage temperature	-40~+70°C
Relative humidity	5%~95% (Non-condensing)

2.8.2 LM3109 Terminal Definition & Wiring

- 1M/2M/3M is common terminal of DI, connect to 24VDC +/- terminal corresponding to source/sink DI.
- DO 1L+/2L+/3L+/4L+ and 1L-/2L-/3L-/4L- connect to load drive power supply 24VDC + and – terminals; it can either be DC or AC power.
- * means no wiring or no physical connection.

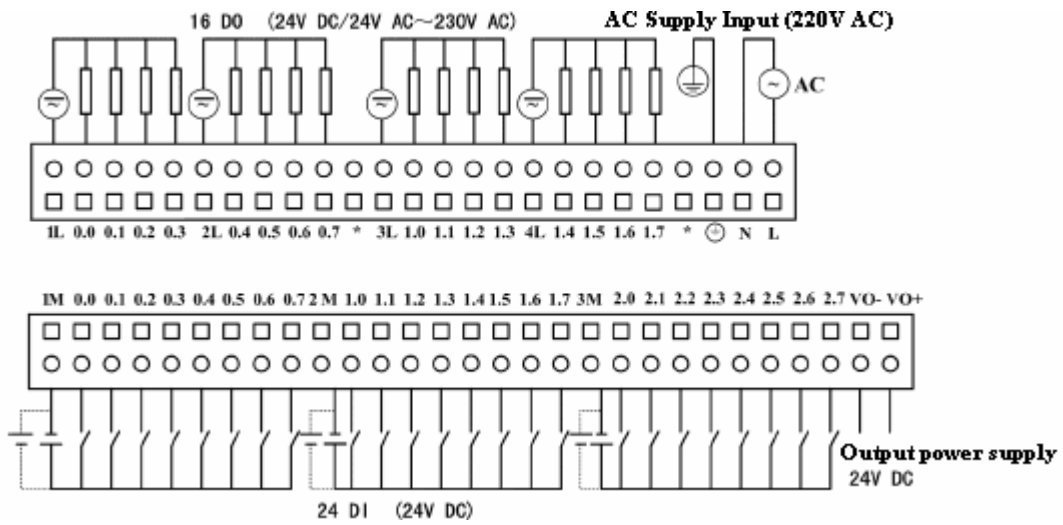

Figure 2-8-1 LM3109 Terminal Definition & Wiring



PLC input power supply wiring must be done under all power-off . Pulling/drawing PLC power supply lines is not allowed when PLC power-on.

◇ LM3109 Terminal Maker Definition

Upper terminals	Terminal descriptions	Lower terminals	Terminal descriptions
1L	DO common terminal	1M	DI common terminal
Q0.0	Normal output terminal	10.0	Normal input/High-speed counting input terminal
Q0.1	Normal output terminal	10.1	Normal input/High-speed counting input control terminal
Q0.2	Normal output terminal	10.2	Normal input/High-speed counting input terminal
Q0.3	Normal output terminal	10.3	Normal input/High-speed counting input control terminal
2L	DO common terminal	10.4	Normal input/High-speed counting input terminal
Q0.4	Normal output terminal	10.5	Normal input/High-speed counting input control terminal
Q0.5	Normal output terminal	10.6	Normal input/High-speed counting input/Interruption input/Pulse catch input terminal
Q0.6	Normal output terminal	10.7	Normal input/Interruption input/Pulse catch

			input terminal
Q0.7	Normal output terminal	2M	DI common terminal
*	–	I1.0	Normal input/Interruption input/Pulse catch input terminal
3L	DO common terminal	I1.1	Normal input/Interruption input/Pulse catch input terminal
Q1.0	Normal output terminal	I1.2	Normal input terminal
Q1.1	Normal output terminal	I1.3	Normal input terminal
Q1.2	Normal output terminal	I1.4	Normal input terminal
Q1.3	Normal output terminal	I1.5	Normal input terminal
4L	DO common terminal	I1.6	Normal input terminal
Q1.4	Normal output terminal	I1.7	Normal input terminal
Q1.5	Normal output terminal	3M	DI common terminal
Q1.6	Normal output terminal	I2.0	Normal input terminal
Q1.7	Normal output terminal	I2.1	Normal input terminal
*	–	I2.2	Normal input terminal
⊕	Ground protection	I2.3	Normal input terminal
N	Neutral	I2.4	Normal input terminal
L	Line	I2.5	Normal input terminal
		I2.6	Normal input terminal
		I2.7	Normal input terminal
		VO-	-24VDC output power supply terminal
		VO+	+24VDC output power supply terminal

2.8.3 LM3109 Communication Function

A standard RS232 and a RS485 serial communication interface.

2.8.4 LM3109 Equivalent Circuit

- ✧ Input channel (DI) equivalent circuit is the same as the input channel of LM3104. Please see Figure 2-2-3.
- ✧ Output channel (DO) equivalent circuit is the same as the output channel of LM3105. Please see Figure 2-3-2.

2.8.5 LM3109 Software Configurations

LM3109 software configuration is similar to LM3104; please see Figure 2.2.5 section.

Chapter 3 Expansion Modules

Table 3-1 Expansion Modules

Type	Model	Description	Specification
Digital Expansion Module	LM3210	8 channel digital input module	DI 8×DC24V
	LM3211	8 channel AC digital input module	DI 8×AC220V
	LM3212	16 channel digital input module	DI 16×DC24V
	LM3220	8 channel transistor output module	DO 8×DC24V Transistor
	LM3221	16 channel transistor output module	DO 16×DC24V Transistor
	LM3222	8 channel relay output module	DO 8×Relay
	LM3223	16 channel relay output module	DO 16×Relay
	LM3230	4 channel DI/4 channel transistor output module	DI 4×DC24V/ DO 4×DC24V Transistor
	LM3231	4 channel DI/4 channel relay output module	DI 4×DC24V/ DO 4×Relay
Analog Expansion Module	LM3310	4 channel analog input module	4~20mA/0~20mA/0~10V
	LM3310A	4 channel analog input module	4~20mA/0~20mA/0~10V
	LM3310B	4 channel analog input module	4~20mA/0~20mA/0~10V
	LM3311	4 channel thermocouple input module	J、K、E、N、T、B、R、S type, -80~80mV
	LM3312	4 channel RTD input module	Cu50、Pt100 type
	LM3313	8 channel analog input module	-10~10V,-20~20mA
	LM3314	8 channel NTC input module	R25=10K, B value selection
	LM3320	2 channel analog output module	0~20mA/0~10V
	LM3330	4 channel analog input/1 channel analog output module	Input: 4~20mA/0~20mA/0~10V/ output: 0~20mA/0~10V
Special Function Module	LM3401	Profibus-DP slave module	
	LM3403	Ethernet Module	

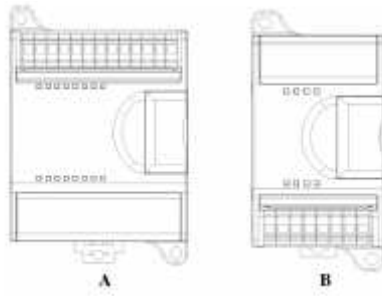

Figure 3-1 LM Series PLC Expansion Module Front View

3.1 Digital Expansion Modules

3.1.1 8 Channel Digital Input Module LM3210

LM3210 DI signal rated working voltage is 24V.

◇ Specifications

Model		LM3210	
Input Features		Physical Features	
Input channel	8 channels	Dimension	50mm(L)×90mm(W)×70mm(H)
Input type	Sink/source	Weight	110g
Input voltage rated value	24VDC	Power consumption	+24VDC(Expansion bus supply) 0mA
Allowed range	0~30VDC		+24VDC(Expansion supply) 40mA
Logic 1 signal	15~30VDC Allowed minimum current 3mA		+5VDC(Expansion bus supply) 60mA
Logic 0 signal	0~5VDC Allowed maximum current 1mA	Working temperature	0~+55℃
Input delay time	<10ms (rated input voltage)	Storage temperature	-40~+70℃
Isolation mode	Optical-coupler isolation	Relative humidity	5~95%, non-condensing
Isolation group	2 groups		
Isolation endurance voltage	1500VAC		

◇ LED Indicator

Channel LED Indicator Status	Definition
ON	Channel ON
OFF	Channel OFF

◇ Terminal Definition & Wiring Instruction

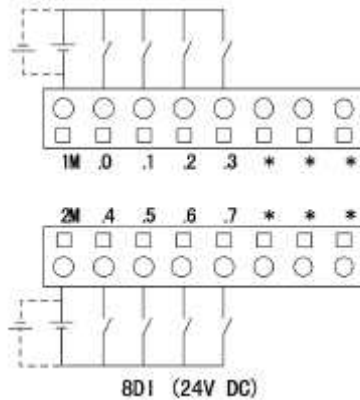

Figure 3-1-1 LM3210 Terminal Wiring Diagram

Description:

- 1M and 2M terminals of DI channel in Figure 3-1-1 indicate external DI common terminals, user can choose to connect terminal M to the positive end or negative end of 24VDC sensor power source in order to adapt to source/sink type DI.
- “*” indicates no wiring or no physical connection.

◇ Equivalent Circuit

- DI channel equivalent circuit is shown in Figure 3-1-2.

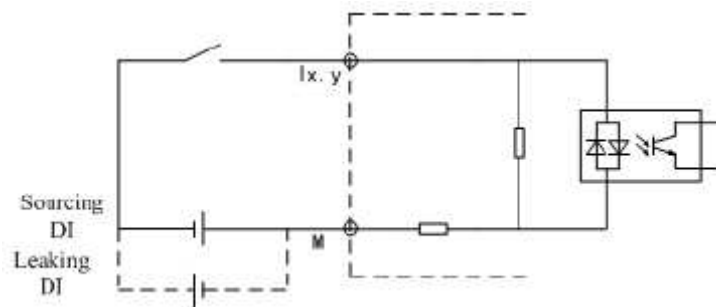

Figure 3-1-2 LM3210 DI Channel Equivalent Circuit

3.1.2 8 Channel AC DI Module LM3211

LM3211 AC DI signal rated working voltage is AC220V.

◇ Specifications

Model		LM3211	
Input Features		Physical Features	
Input channel	8 channels	Dimension	75mm(L)×90mm(W)×70mm(H)
Input voltage rated value	220VAC	Weight	160g
Allowed range	164~264V AC	Power consumption	+24VDC(Expansion bus supply) 0mA
Logic 1 signal (Minimum)	164V AC		+24VDC(External supply) 0mA
Logic 0 signal	80 V AC		+5VDC(Expansion bus supply) 60mA
Input delay time	<20ms (rated input voltage)	Working temperature	0~+55℃
Isolation mode	Optical-coupler isolation	Storage temperature	-40~+70℃
Isolation group	8 groups	Relative humidity	5~95%, no condensation
Isolation endurance voltage	1500VAC		

◇ LED Indicator

Channel LED Indicator Status(Green)	Definition
ON	Channel ON
OFF	Channel OFF

◇ Terminal Definition & Wiring Instruction

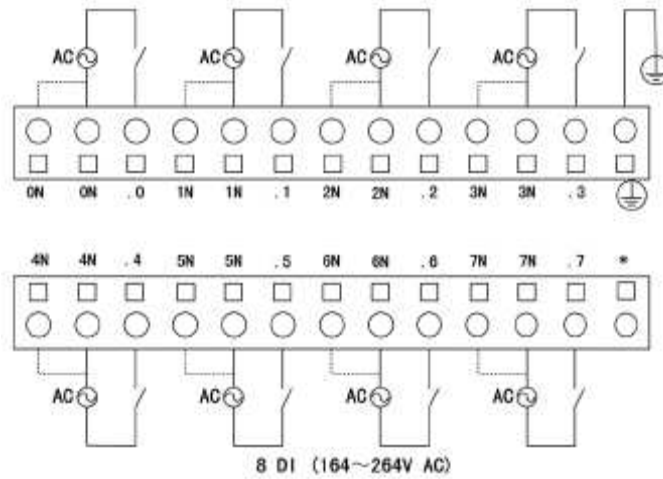

Figure 3-1-3 LM3211 Terminal Definition and Wiring

Description:

- 220VAC input signal connects between mN and m (m stands for number 0 to 7) and mN is connected inside circuit board (shown by broken lines in Figure 3-1-3). The terminal on the right end of upper level terminals can connect ground protection (or earth).
- * indicates no wiring or no physical connection.
- ◇ Equivalent Circuit
- Input channel (DI) equivalent circuit shown in Figure 3-1-4.

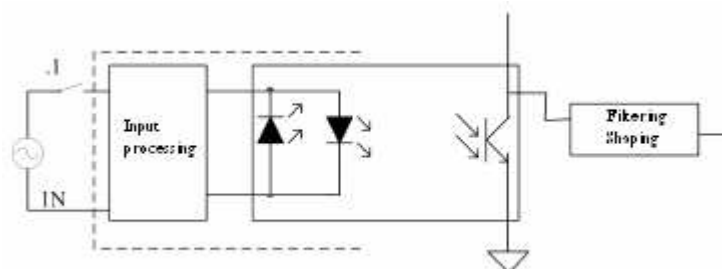

Figure 3-1-4 LM3211 Input Channel (DI) Equivalent Circuit

3.1.3 16 Channel DI Module LM3212

LM3212 DI rated working voltage is 24V.

◇ Specifications

Model		LM3212		
Input Features		Physical Features		
Input channel	16 channels	Dimension	75mm(L)×90mm(W)×70mm(H)	
Input type	Sink/source	Weight	160g	
Input voltage rated value	24V DC	Power consumption	+24VDC(Expansion bus supply)	0mA
Allowed range	0~30V DC		+24VDC (External supply)	80mA
Logic 1 signal	15~30V DC Allowed minimum current 3 mA			
Logic 0 signal	0~5V DC Allowed maximum current 1 mA		+5VDC(Expansion bus supply)	90mA
Input delay time	<10ms (Rated input voltage)	Working temperature	0~+55℃	
Isolation mode	Optical-coupler isolation	Storage temperature	-40~+70℃	
Isolation group	4 groups			
Isolation endurance voltage	1500VAC	Relative humidity	5~95%, non-condensing	

◇ LED Indicator

Channel LED Indicator Status(Green)	Definition
ON	Channel ON
OFF	Channel OFF

◇ Terminal definition and wiring instruction

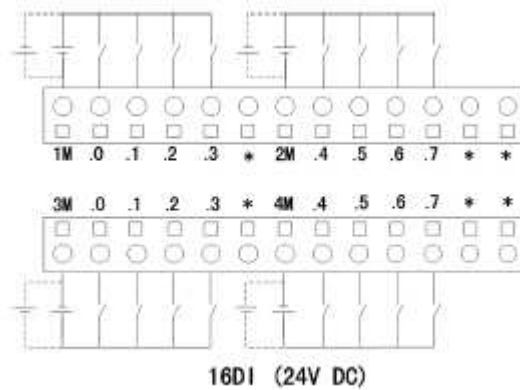

Figure 3-1-5 LM3212 Terminal Definition and Wiring

Descriptions:

- 1M, 2M, 3M and 4M terminals of DI channel in Figure 3-1-5 are external DI common ends, user can choose to connect M terminal to the positive end and negative end of 24VDC sensor power in order to adapt to source/sink type DI.
 - “*” indicates no wiring or no physical connection.
- ◇ Equivalent Circuit
- Input channel (DI) equivalent circuit shown in Figure 3-1-2.

3.1.4 8 Channel Transistor Output Module LM3220

LM3220 module output rated load voltage is 24VDC.

◇ Specifications

Model		LM3220	
Input Features		Physical Features	
Output channel	8 channels	Dimension	50mm(L)×90mm(W)×70mm(H)
Output type	Transistor	Weight	120g
Output voltage	24V DC	Power consumption	+24VDC(Expansion bus supply) 0mA
Allowed range	20.4~28.8V DC		
Transistor Conducting voltage drop	<0.5V(Output logic “1”, current 1 A)	+24VDC (External supply)	According to actual load

Logic 1 max. output current	1A			
Logic 0 max. leakage current	1mA		+5VDC (Expansion bus supply)	100mA
Common end output current total	<4A			
Surge current	<8A, 100ms			
On impedance (Contact impedance)	<0.2Ω			
Short circuit protection	External supply	Working temperature		0~+55℃
Response time	Status “0” to “1”	<1ms	Storage temperature	-40~+70℃
	Status “1” to “0”	<1ms		
Isolation mode	Optical-coupler isolation			
Isolation group	2 groups		Relative humidity	5~95%, non-condensing
Isolation endurance voltage	1500VAC			

◇ LED Indicator

Channel LED Indicator Status(Green)	Definition
ON	Channel ON
OFF	Channel OFF

◇ Terminal Definition & Wiring Instruction

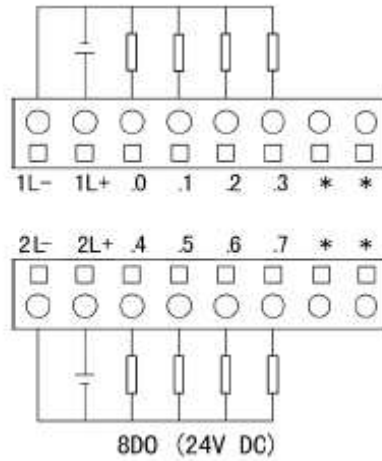

Figure 3-1-6 LM3220 Terminal Definition and Wiring Diagram

Descriptions:

- 1L+ and 1L- of DO channel in Figure 3-1-6 connect the positive and negative end of 24VDC drive power supply under external load; 2L+ and 2L- connect the positive and negative end of another channel (or the same channel) 24VDC.
- “*” means no wiring or no physical connection.

◇ Equivalent Circuit

- DO channel equivalent circuit is shown in Figure 3-1-7.

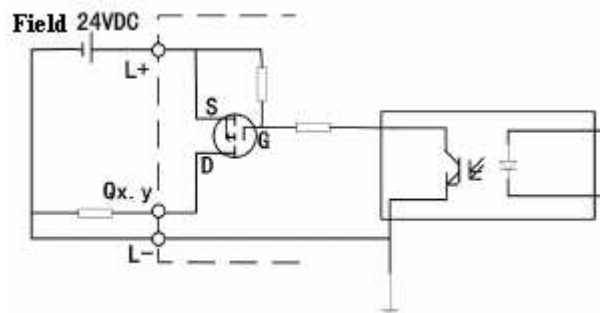

Figure 3-1-7 LM3220 DO Channel Equivalent Circuit

3.1.5 16 Channel Transistor Output Module LM3221

LM3221 output rated load voltage is 24VDC.

◇ Specifications

Model		LM3221		
Input Features		Physical Features		
Output channel	16 channels	Dimension	75mm(L)×90mm(W)×70mm(H)	
Output type	Transistor	Weight	170g	
Output voltage	24V DC	Power consumption	+24VDC(Expansion bus supply) 0mA	
Allowed range	20.4~28.8V DC			
Transistor Conducting voltage drop	<0.5V(Output logic "1",current 1 A)		+24VDC (External supply)	According to actual load
Logic 1 max. output current	1A		+5VDC (Expansion bus supply)	180mA
Logic 0 max. leakage current	1mA	Working temperature	0~+55°C	
Common end output current total	<4A			
Surge current	<8A, 100ms			
On impedance (Contact impedance)	<0.2Ω			
Short circuit protection	External supply	Storage temperature	-40~+70°C	
Response time	Status "0" to "1"			<1ms
	Status "1" to "0"			
Isolation group	4 groups	Relative humidity	5~95%, non-condensing	
Isolation mode	Optical-coupler isolation			
Isolation endurance voltage	1500VAC			

◇ LED Indicator

Channel LED Indicator Status(Green)	Definition
ON	Channel ON
OFF	Channel OFF

◇ Terminal Definition & Wiring

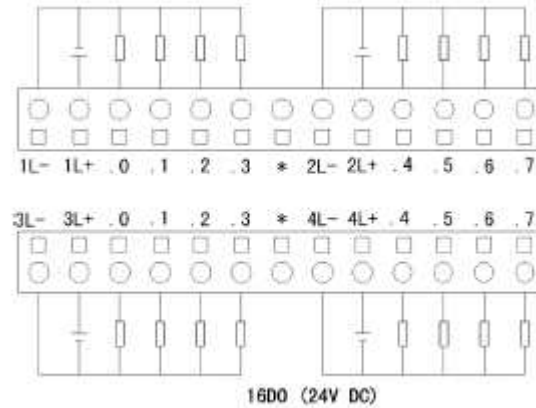

Figure 3-1-8 LM3221 Terminal Definition & Wiring Diagram

Descriptions:

- 1L+ and 1L- of DO channel in Figure 3-1-8 connect the positive and negative end of 24VDC drive power supply under external load, 2L+,2L-,3L+,3L-,4L+ and 4L- connect the positive and negative end of another channel (or the same channel) 24VDC .
- “*” means no channel or no physical connection.

◇ Equivalent Circuit

- Output channel (DO) equivalent circuit is shown in Figure 3-1-7.

3.1.6 8 Channel Relay Output Module LM3222

LM3222 output rated load is 24VDC or 220VAC.

◇ Specifications

Model		LM3222	
Output Features		Physical Features	
Output channel	8 channels	Dimension	50mm(L)×90mm(W)×70mm(H)
Output type	Relay	Weight	140g

Output voltage	24V DC or 24~230VAC	Power consumption	+24VDC(Expansion bus supply)	40mA
Allowed range	5~30V DC or 5~250VAC		+24VDC (External supply)	According to actual load
Common end output current total	<10 A		+5VDC (Expansion bus supply)	60mA
Output On/Off capacity	2A, Resistance load			
Minimum load	10mA(Voltage between contacts 5VAC or 5VDC)	Working temperature		0~+55°C
Over current protection	None			
On impedance	<0.2Ω			
Isolation group	2 groups			
Isolation voltage between coil and contact	3000VAC,1 minute, leakage current 1mA	Storage temperature		-40~+70°C
Isolation resistance(minimum)	Between contacts or between coil and contact are both 100MΩ(500VDC)			
Contact On/Off delay time	<10ms			
Contact On/Off frequency (max)	1Hz	Relative humidity		5~95%, non-condensing
Relay mechanical life	No load: over 10,000,000 times; Rated resistance 2A load: over 100,000 times			

◇ LED Indicator

Channel LED Indicator Status(Green)	Definition
ON	Channel ON
OFF	Channel OFF

◇ Terminal Definition & Wiring

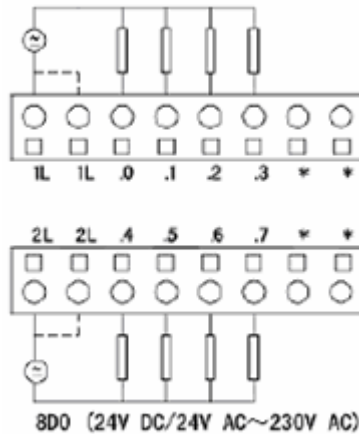

Figure 3-1-9 LM3222 Terminal Definition & Wiring

Descriptions:

- 1L and 2L of DO channel in Figure 3-1-9 are load drive supply terminals of two groups output, it can be either DC or AC supply.
- 1L and 1L, 2L and 2L are connected inside circuit board (shown by broken line in Figure3-1-9).
- “*” means no wiring or no physical connection.

◇ Equivalent Circuit

- Output channel (DO) equivalent circuit is shown in Figure 3-1-10.

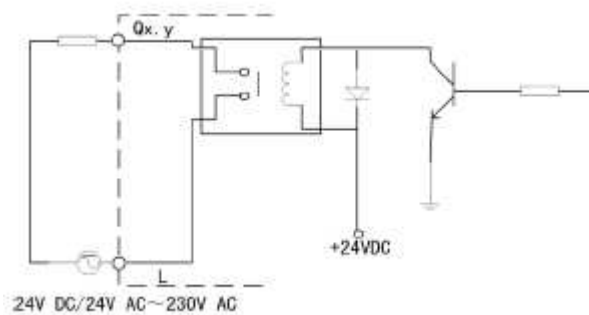

Figure 3-1-10 LM3222 Output Channel (DO) Equivalent Circuit

3.1.7 16 Channel Relay Output Module LM3223

LM3223 output rated load is 24VDC or 220VAC.

◇ Specifications

Model		LM3223		
Output Features		Physical Features		
Output channel	16 channels	Dimension	75mm(L)×90mm(W)×70mm(H)	
Output type	Relay	Weight	200g	
Output voltage	24VDC or 24~230V AC	Power consumption	+24VDC(Expansion bus supply)	80mA
Allowed range	5~30VDC or 5~250VAC		+24VDC(External supply)	According to actual load
Common end output current total	<10A		+5VDC(Expansion bus supply)	120mA
Output On/Off capacity	2A, Resistance load	Working temperature	0~+55℃	
Min. load	10mA(Voltage between contacts 5VAC or 5VDC)	Storage temperature	-40~+70℃	
		Relative humidity	5~95%, no condensation	
Over current protection	None	Output features		
On impedance	<0.2Ω	Isolation resistance (min)	100MΩ between contacts or between coil and contact (500VDC)	
Isolation group	4 groups	Contact On/Off delay time	<10ms	
Isolation voltage between coil and contact	3000VAC, 1 minute, leakage current 1mA	Contact On/Off frequency (max)	1Hz	
Isolation voltage between contacts	750VAC, 1 minute, leakage current 1mA	Relay mechanical life	No load: over 10,000,000 times; Rated resistance 2A load: over 100,000 times	

◇ LED Indicator

Channel LED Indicator Status(Green)	Definition
ON	Channel ON
OFF	Channel OFF

◇ Terminal Definition & Wiring

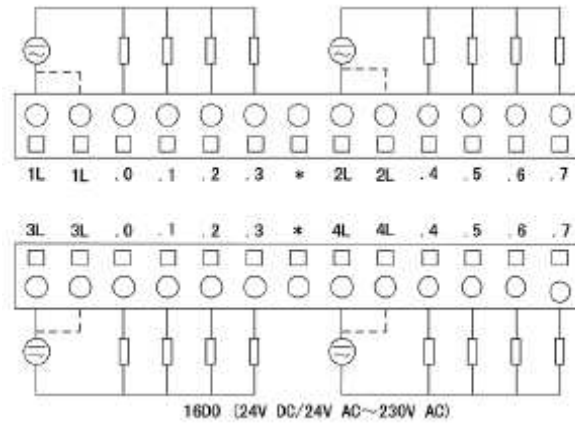

Figure 3-1-11 LM3223 Terminal Definition & Wiring

Descriptions:

- 1L, 2L, 3L and 4L of DO channel in Figure 3-1-11 are load drive supply terminals of four groups output. It can be either DC or AC supply.
- mL is connected inside circuit board (shown by broken line in Figure 3-1-11).
- “*” means no wiring or no physical connection.

◇ Equivalent Circuit

- Output channel (DO) equivalent circuit is shown in Figure 3-1-10.

3.1.8 4 Channel DI/4 Channel Transistor Output Module LM3223

LM3230 module includes 4 DI channels and 4 transistor output channels, the rated working voltage of DI signals is 24VDC, output rated load voltage is 24VDC.

◇ Specifications

Model		LM3230		
Input Features		Physical Features		
Input channel	4 channels	Dimension	50mm(L)×90mm(W)×70mm(H)	
Input type	Relay	Weight	120g	
Input voltage rated value	24VDC	Power consumption	+24VDC(Expansion bus supply)	0mA
Allowed range	0~30VDC		+24VDC(External supply)	Input 20Ma,output according to actual load
Logic 1 signal	15~30VDC, allowed minimum		+5VDC(Expansion bus supply)	90mA

	current 3 mA		
Logic 0 signal	0~5VDC, allowed maximum current 1mA	Working temperature	0~+55°C
Input delay time	<10ms(rated input voltage)	Storage temperature	-40~+70°C
Isolation mode	Optical-coupler isolation	Relative humidity	5~95%, non-condensing
Isolation group	1 group		
Isolation endurance voltage	1500VAC		
Output features			
Logic “1” single output max. current	1A	Logic “0” single output max. current	1mA
Output channel	4 channel	Surge current	<8A, 100ms
Output type	Transistor	On impedance (Contact impedance)	<0.2Ω
Output voltage	24VDC	Short circuit protection	External supply
Allowed range	20.4~28.8VDC	Response time	Status “0” to “1” <1ms
Transistor conducting voltage drop	<0.5V(Output logic “1”,current 1A)		Status “1” to “0” <1ms
		Isolation group	1 group
Isolation mode	Optical-coupler isolation	Isolation endurance voltage	1500VAC

◇ LED Indicator

Channel LED Indicator Status(Green)	Definition
ON	Channel ON
OFF	Channel OFF

◇ Terminal Definition & Wiring

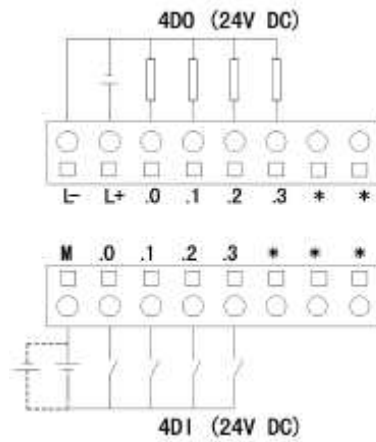

Figure 3-1-12 LM3230 Terminal Definition & Wiring

Descriptions:

- M end of DI channel in Figure 3-1-12 is the common end of external DI, user can choose to connect M end to the positive or negative end of sensor power supply 24VDC to adapt to source/sink type DI.
- L+ and L- of DO channel in Figure 3-1-12 are the positive and negative ends of 24VDC external load drive power supply.
- “*” means no wiring or no physical connection.

◇ Equivalent Circuit

- Input channel (DI) equivalent circuit is shown in Figure 3-1-2.
- Output channel (DO) equivalent circuit is shown in Figure 3-1-7.

3.1.9 4 Channel DI/4 Channel Relay Output Module LM3231

LM3231 module includes 4 DI processing channels and 4 channel relay output processing channels, output rated load voltage is 24VDC or 220VAC.

◇ Specifications

Model		LM3231	
Input Features		Physical Features	
Input channel	4 channels	Dimension	50mm(L)×90mm(W)×70mm(H)
Input type	Sink/source	Weight	120g
Input voltage	24V DC	Power consumption	+24VDC (Expansion bus supply)
Allowed range	0~30V DC		
Logical 1 signal	15~30V DC		+24VDC(External supply)
	allowed minimum	1 supply)	Output according to actual load

	current 3mA		
Logical 0 signal	0~5V DC allowed maximum current 1mA	+5VDC(External bus supply)	90mA
Input delay time	<10ms(Rated input voltage)	Working temperature	0~+55°C
Isolation mode	Optical-coupler isolation	Storage temperature	-40~+70°C
Isolation group	1 group	Relative humidity	5~95%, non-condensing
Isolation endurance voltage	1500VAC		
Output Features			
Output channel	4 channels	On impedance	<0.2Ω
Output type	Relay	Isolation group	1 group
Output voltage	24V DC or 24~ 230V AC	Isolation voltage between coil and contact	3000VAC, 1 minute, leakage current 1mA
		Isolation voltage between contacts	750VAC, 1 minute , leakage current 1mA
Allowed range	5~30VDC or 5~ 250V AC	Isolation resistance (minimum)	Between contacts or between coil and contact are both 100MΩ (500VDC)
Common end output current total	<10A	Contact On/Off delay time	<10ms
Output On/Off capacity	2A, Resistance load	Contact On/Off frequency(max)	1Hz
Min load	10mA (Voltage between contacts 5VAC or 5VDC)	Relay mechanical life	No load: over 10,000,000 times; Rated resistance 2A load: over 100,000 times
Over current protection	None		

◇ LED Indicator

Channel LED Indicator Status(Green)	Definition
ON	Channel ON
OFF	Channel OFF

◇ Terminal Definition & Wiring

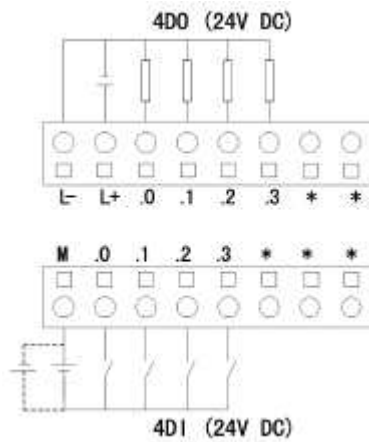

Figure 3-1-13 LM3231 Terminal Definition & Wiring

Descriptions:

- M end of DI channel in Figure 3-1-13 is the common end of external DI, user can choose to connect M end to the positive or negative end of 24VDC sensor power supply to adapt to source/sink DI.
- L end of DO channel in Figure 3-1-13 is the output load drive supply terminal. It can be either DC or AC supply.
- L and L connected inside circuit board. (shown by broken line in Figure)
- “*” means no wiring or no physical connection.

◇ Equivalent Circuit

- Input channel (DI) equivalent circuit is shown in Figure 3-1-2.
- Output channel (DO) equivalent circuit is shown in Figure 3-1-10.

3.2 Analog Expansion Module

3.2.1 4 Channel Analog Input Module LM3310

LM3310 power supply is 24VDC respectively.

◇ Specifications

Model			LM3310	
Input Features			Physical Features	
Input channel	4 channels		Dimension	75mm(L)×90mm(W)×70mm(H)
Input	Voltage	0~10V	Weight	170g

	Current	0~20mA	Power consumption		
	Current	4~20mA			
Input precision (monopole)	0.5%FS@25°C (FS means full range,@25°C means at 25°C)				
Input type	difference				
CM voltage	Signal voltage +CM voltage<13V				
CMMRR	>60dB (DC to 50Hz)				
A/D conversion time	<200μs				
Input impedance	>1MΩ (Voltage) 250Ω (Current)				
Maximum input current	<30mA				
Maximum input voltage	<30V				
Temperature drift	±100ppm/°C				
Isolation mode	Isolation between field & system digital part; no isolation between channels	Working temperature	0~+55°C		
Isolation endurance voltage	1000VDC	Storage temperature	-40~+70°C		
Sampling refresh time (every 4 channels)	6ms	Relative humidity	5~95%, non-condensing		

◇ LED Indicator

Module Status	Power Indicator
Working normally	on
Power not connected or working abnormally	off

◇ Input Channel Signal Type & Range

Table3-2-1 Relationship between Input Signal Range & Input Data Range

Signal mode	Range	Corresponding Data Range	
		Decimal value	Hex value
Voltage signal	0~10V	0~65535	0x00~0xFFFF
Current signal	0~20mA	0~65535	0x00~0xFFFF
Current signal	4~20mA	0~65535	0x00~0xFFFF

◇ Terminal Definition & Wiring

LM3310 module provides 4 analog input channels. See Figure3-2-1 for terminal definition and typical field wiring.

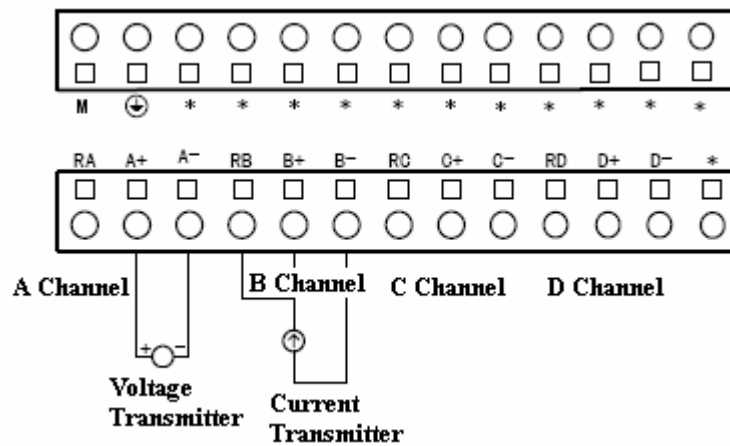

Figure3-2-1 LM3310 Terminal Definition & Wiring

Description:

- M means negative end of internal analog processing circuit, if input signal is not in the CM voltage range defined in the technical specifications, please connect the negative end of input signal to M to obtain steady measuring value.
- “⊕” means the channel connect ground protection. Can connect cabinet ground, provide static release channel for internal analog processing circuit.
- Lower level terminals are signal input channels. Input signal can be either voltage or current signals. In Figure3-2-1, when input signal is voltage signal, A+ connects the positive end of voltage transmitter and A- connects its negative end. When input signal is current signal, short connect RA and A+ connect the positive end of current transmitter, A- connects the negative end of current transmitter.
- Figure3-2-2 and Figure 3-2-3 are LM3310 wiring with 2-wire and 4-wire current transmitter. 2-wire current transmitter adopts external power supply, user can choose to use 24VDC output power of CPU module according to power capacity demand, or connect other external power.
- “*” means no wiring or no physical connection.

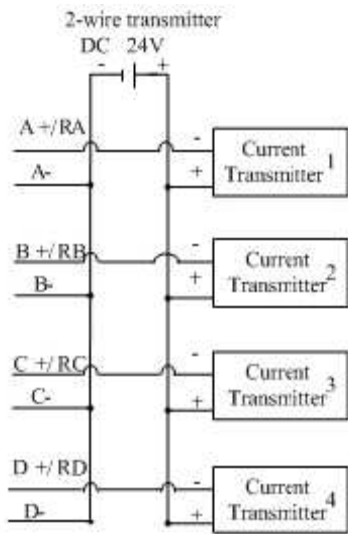

Figure3-2-2 2-Wire Current Transmitter Wiring

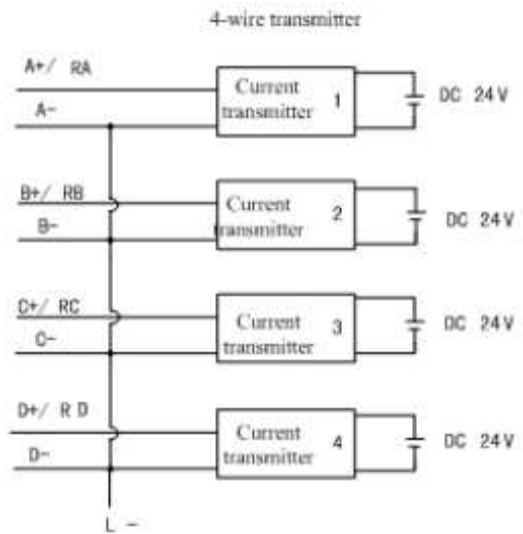

Figure3-2-3 4-Wire Current Transmitter Wiring

◇ Equivalent circuit

Input channel (AI) (voltage, current signal input) equivalent circuit is shown in Figure 3-2-4.

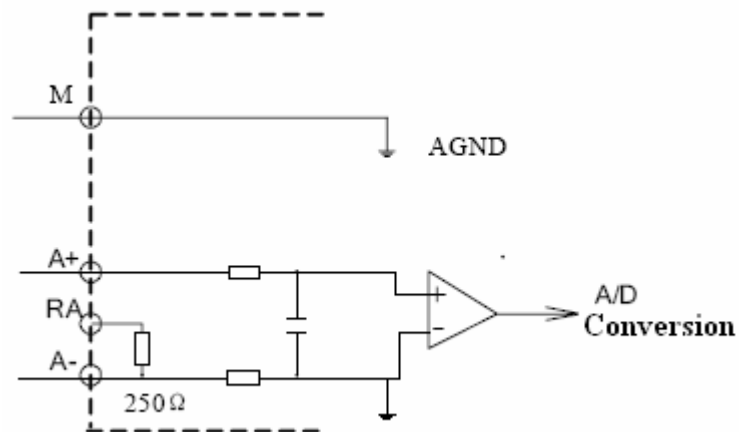

Figure3-2-4 LM3310 Input Channel Equivalent Circuit

◇ Software Configuration

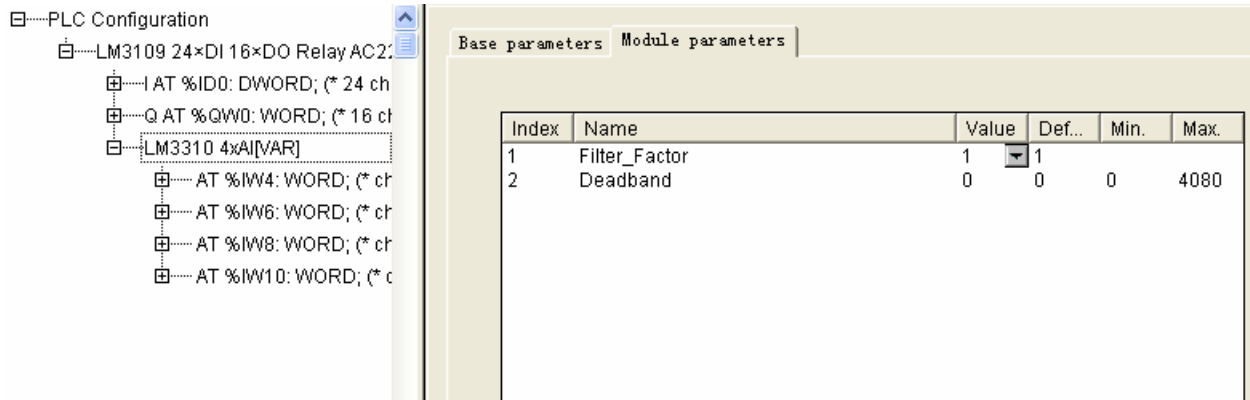

Figure3-2-5 LM3310 Software Configuration

LM3310 uses four input words, see Figure for IW2, IW4, IW6 and IW8. Each word means one channel, the first, the second, the third and the fourth channel. By clicking LM3310, display the menu on the right as shown in Figure 3-2-5 to configure the Filter parameters of LM3310.

- Filter Parameter: Filter parameters, its value could be 1, 2, 4, 8, 16 and 32. Filter parameter correspond to time value of RC lowpass, as shown in table 3-2-2. For filter parameter, the default value is selected if there is no special request.
- Dead band means dead area value, the value range is 0~4080. When start filter functions, if the difference between the current collected result of analog value and the value after last filtering exceeds the set dead area value, LM3310 output current collected result value directly; otherwise output the conversion result after filtering. Dead area value equal 0 means forbidden dead area parameter.

Table3-2-2 Relationship between filter parameter and the time value of RC lowpass

Filter Parameter Value	Corresponding the time value of RC lowpass
1 (Default value)	(no filter)
2	80ms
4	160ms
8	320ms
16	640ms
32	1280ms

Choose to click one of the channels and appears the menu as shown in Figure 3-2-6.

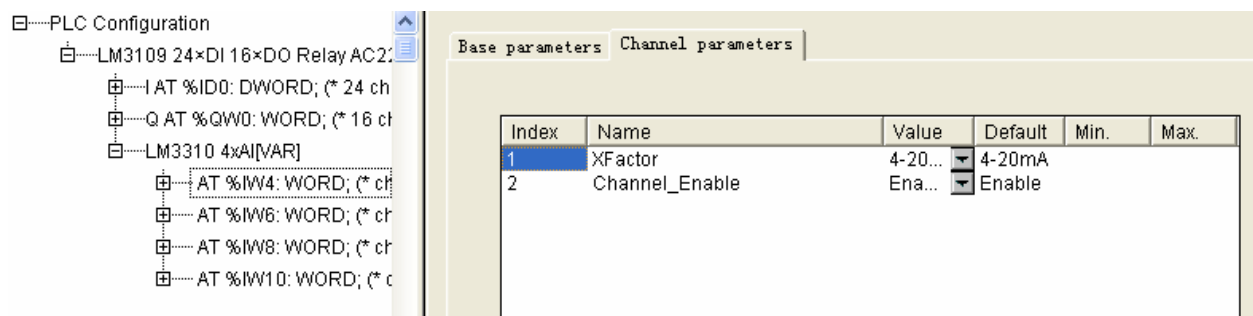

Figure3-2-6 LM3310 Channel Configuration

- XFactor is input signal of selected channels, select 4-20mA,0-20mA or 0-10V, the default value is 4-20mA;
- Channel_Enable is channel enable selection, please select Enable.

i Note: LM3310 channel parameter setup must accord with actual input signal. Regarding the rest items of software configuration, please refer to software manual.

3.2.2 4-Channel Analog Input Module LM3310A

The difference between LM3310 and LM3310A is LM3310 adopts Pseudo-Differential Inputs and LM3310A adopts Single-Ended Inputs.

◇ Specifications

Model		LM3310A			
Input Features		Physical Features			
Input channel	4 channels	Dimension	75mm(L)×90mm(W)×70mm(H)		
Input Ranges	Voltage	0~10V	Weight	170g	
	Current	0~20mA			
	Current	4~20mA			
Input precision (monopole)	0.5%FS@25°C (FS means full range,@25°C means at “25°C”)		Power consumption	+24VDC (Expansion bus supply)	10mA
Input type	Single terminal				
A/D conversion time	<200μs				
Input impedance	>1MΩ(voltage)			+5VDC	40mA

	250Ω(Current)		(Expansion bus supply)
Max. input current	<30mA		
Max. input voltage	<30V		
Temperature drift	±100ppm/°C		
Isolation mode	No isolation between field & system internal, isolation between channels	Working temperature	0~+55°C
Isolation endurance voltage	1000VDC	Storage temperature	-40~+70°C
Sampling refresh time (every four channels)	6ms	Relative humidity	5%~95%, non-condensing

◇ LED Indicator

Module Status	Power Indicator
Working normally	on
Power not connected or working abnormally	off

◇ Input Channel Signal Type & Range

Table3-2-3 Relationship between Input Signal Range and Input Data Range

Signal mode	Range	Corresponding Input Data Range	
		Decimal value	Hex value
Voltage signal	0~10V	0~65535	0x00~0xFFFF
Current signal	0~20mA	0~65535	0x00~0xFFFF
Current signal	4~20mA	0~65535	0x00~0xFFFF

◇ Terminal Definition & Wiring description

See Figure3-2-7 for terminal definition and typical field wiring of LM3310A 4 analog input channels.

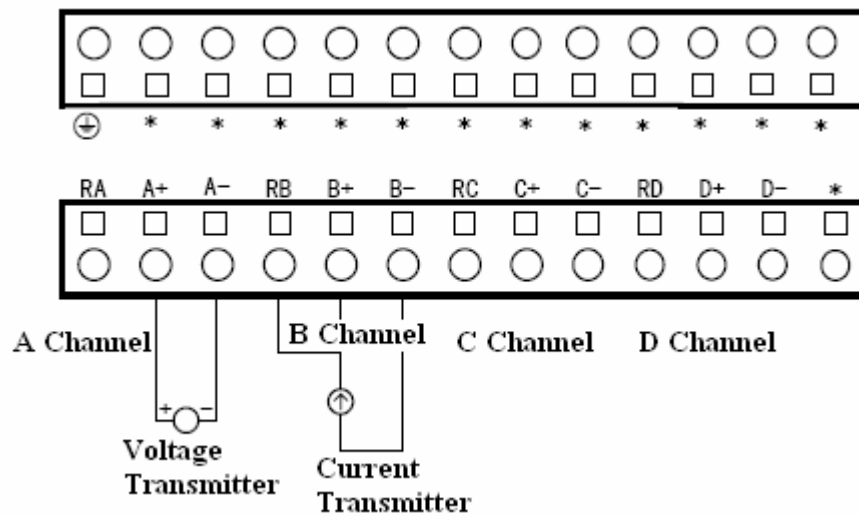

Figure3-2-7 LM3310A Terminal Definition & Wiring

Description:

- “⊕” means the channel connect ground protection. Connect cabinet ground, provide static release channel for internal analog processing circuit.
- Lower level terminals are signal input channels. Input signal can be either voltage or current signals. In Figure3-2-7, when input signal is voltage signal, A+ connects the positive end of voltage transmitter and A- connects its negative end. When input signal is current signal, short connect RA and A+ connect the positive end of current transmitter, A- connects the negative end of current transmitter.
- Figure3-2-8 and Figure 3-2-9 are wiring with 2-wire and 4-wire current transmitter. 2-wire current transmitter adopts external power supply, user can choose to use 24VDC output power of CPU module according to power capacity demand, or connect other external power.
- “*” means no wiring or no physical connection in this channel.

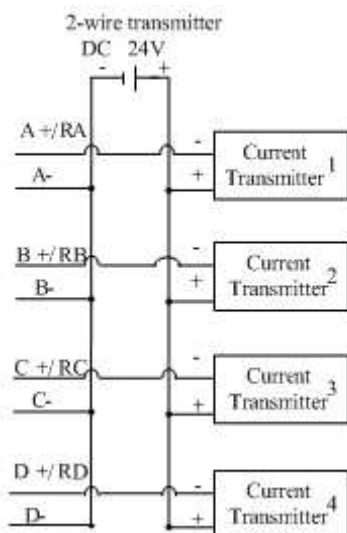

Figure3-2-8 2-wire current transmitter wiring

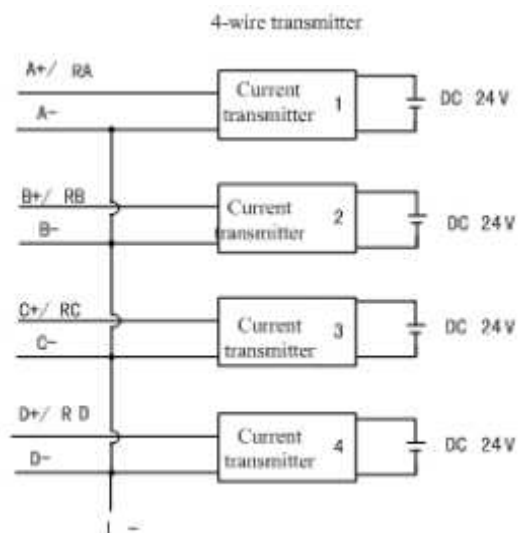

Figure3-2-9 4-wire current transmitter wiring

◇ Equivalent Circuit

Input channel (AI) (voltage, current signal input) equivalent circuit is shown in Figure3-2-10.

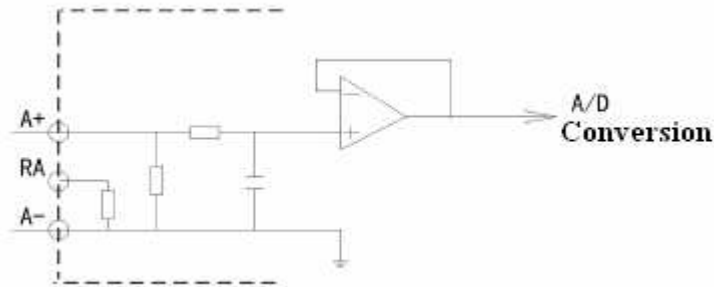

Figure3-2-10 LM3310A Input Channel Equivalent Circuit

◇ Software Configuration

To LM3310A software configuration, PLC type is LM3310. Software parameter configuration is the same as LM3310. Please refer to 3.2.1 section for LM3310 software configuration portion.

i Note: LM3310A adopts Single-Ended Inputs, can only connect one transmitter if transmitter negative terminals can not be short connected.

3.2.3 4-Channel Analog Input Module LM3310B

LM3310B adopts Single-Ended Inputs and its data processing precision is higher than LM3310, resolution is 16 bit.

◇ Specifications

Model		LM3310A		
Input Features		Physical Features		
Input channel	4 channels	Dimension	75mm(L)×90mm(W)×70mm(H)	
Input ranges	Voltage	0~10V	Weight	170g
	Current	0~20mA	Power consumption	+24VDC (Expansion bus supply)
	Current	4~20mA		
Input precision (monopole)	0.5%FS@25°C (FS means full range,@25°C means at “25°C”)			0mA

Input type	Single terminal		+24VDC (External supply)	30mA
A/D conversion time	<200 μ s			
Input impedance	>1M Ω (voltage) 250 Ω (Current)			
Max. input current	<30mA		+5VDC (Expansion bus supply)	60mA
Max. input voltage	<30V			
Temperature drift	\pm 100ppm/ $^{\circ}$ C			
Isolation mode	Isolation between field & system internal, no isolation between channels	Working temperature	0 \sim +55 $^{\circ}$ C	
Isolation endurance voltage	1000VDC	Storage temperature	-40 \sim +70 $^{\circ}$ C	
Sampling refresh time (every four channels)	680ms	Relative humidity	5% \sim 95%, non-condensing	

◇ LED Indicator

Module Status	Power Indicator
Working normally	on
Power not connected or working abnormally	off

◇ Input Channel Signal Type & Range

Table3-2-4 Relationship between Input Signal Range and Input Data Range

Dial switch setup	Signal mode	Range	Corresponding Input Data Range	
			Decimal value	Hex value
OFF	Voltage signal	0 \sim 10V	0 \sim 65535	0x00 \sim 0xFFFF
OFF	Current signal	0 \sim 20mA	0 \sim 65535	0x00 \sim 0xFFFF
ON	Current signal	4 \sim 20mA	0 \sim 65535	0x00 \sim 0xFFFF

✧ Terminal Definition & Wiring description

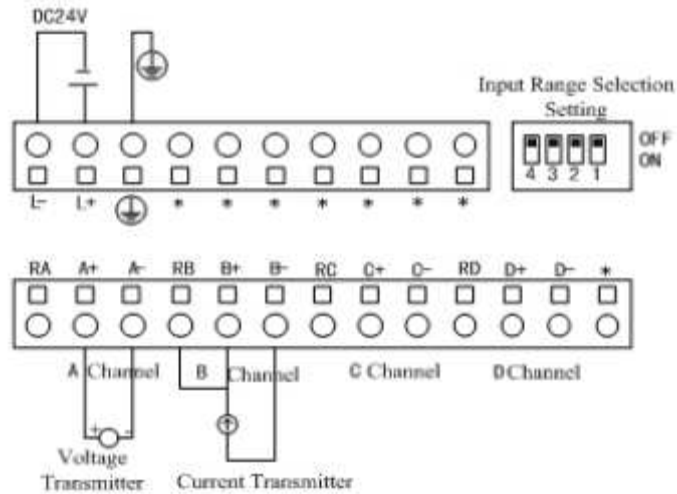

Figure3-2-11 LM3310B Terminal Definition and Wiring

Description:

- L+ and L- in Figure 3-2-11 are the positive end and negative end of external 24V DC power;
- Lower level terminals are signal input channels, input signal can be either voltage or current signals. In Figure3-2-11, when input signal is voltage signal, A+ connects the positive end of voltage transmitter and A- connects its negative end. When input signal is current signal, short connect RA and A+ connects the positive end of current transmitter, A- connects the negative end of current transmitter;
- Figure3-2-12 and Figure 3-2-13 are wiring with 2-wire and 4-wire current transmitter. 2-wire current transmitter adopts external power supply, user can choose to use 24VDC output power of CPU module according to power capacity demand, or connect other external power.
- Each of 4 input channels corresponds to each bit of 4-bit dial switch, as shown in table 3-2-5;

Table3-2-5 Relationship between Input Signal Channel & 4-bit Dial Switch

Channel No.	A	B	C	D
Dial Switch Position	1	2	3	4

- Input range selection switch is on the right side of upper level terminals. 4-bit dial switch correspond to 4 AI channels to setup the types and ranges of corresponding input channels. The relationship between dial switch selection and input signal type are shown in table 3-2-4;
- “⊕” means the channel connect ground protection;
- “*” means no wiring or no physical connection in this channel.

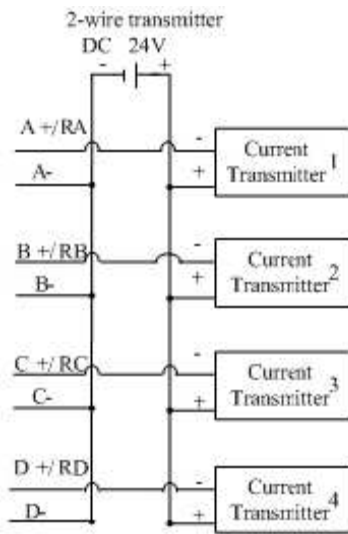

Figure3-2-12 2-wire current transmitter wiring

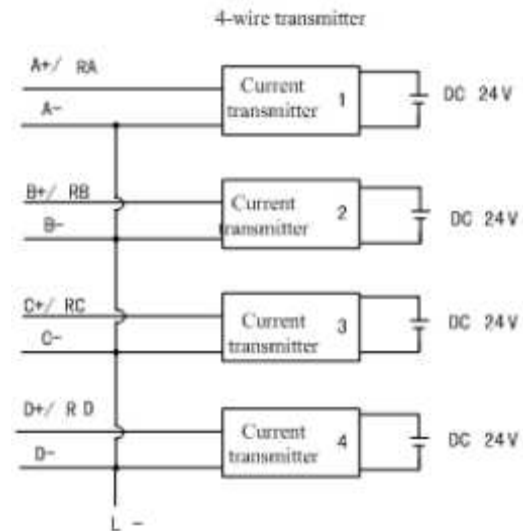

Figure3-2-13 4-wire current transmitter wiring

◇ Equivalent Circuit

Input channel (AI) (voltage, current signal input) equivalent circuit is shown in Figure 3-2-14.

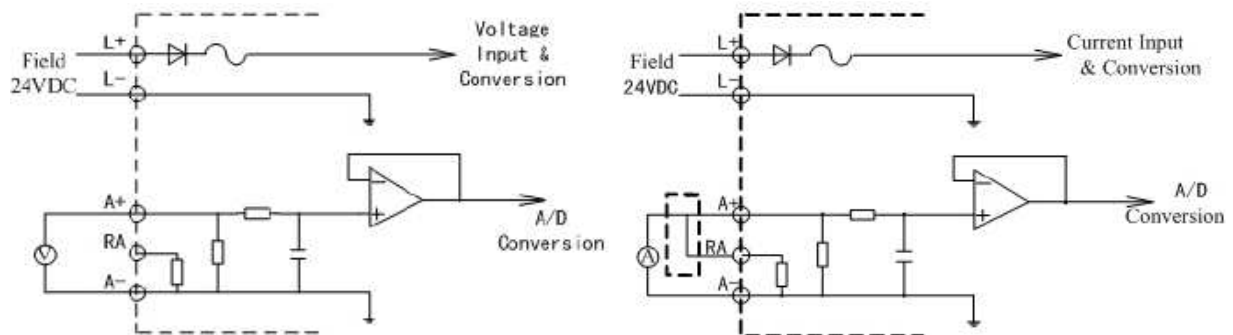

Figure3-2-14 LM3310B Voltage, Current Input Channel Equivalent Circuit

◇ Software Configuration

To LM3310B software configuration, PLC type is LM3310. The corresponding time values of LM3310B filter parameter shown in following table. The dead area parameter is invalid because LM3310B is not fast acquisition module. The rest setup is the same as LM3310. Please refer to 3.2.1 section software configuration portion.

Table3-2-6 Relationship between LM3310B filtering parameter and time value

Filter parameter value	Corresponding time value of RC lowpass filter
1 (Default value)	(no filter)
2	1s
4	1.6s

8	2.8s
16	4.2s
32	4.2s

i Note: LM3310B adopts Single-Ended Inputs, can only connect one transmitter if transmitter negative terminals can not be short connected.

3.2.4 4 Channel Thermocouple Input Module LM3311

LM3311 collects and processes thermocouple milli-volt voltage signals from field.

☆ Specifications

Model		LM3311	
Input Features		Physical Features	
Input channel	4 channels	Dimension (W*H*D)	75mm(L)×90mm(W) ×70mm(H)
Input signal	J、K、T、N、E、R、S、B type thermocouple, -80~80mV	Weight	160g
Input precision	0.1%FS@ (25°C, ±80mV (voltage))(FS means full range, @25°C means 25°C)	Power consumption	+24VDC(Expansion supply) 0mA
Temperature differential rate	0.1°C		
Cold end error	±1.5°C		+5VDC(Expansion supply) 100mA
Input impedance	>1MΩ		
NMMRR	Better than 70dB@50Hz (filter factor is 8, 16, 32)	Working temperature	0~+55°C
Temperature drift	±50ppm/°C		
Isolation mode	Isolation between field & system digital part, no isolation between channels	Storage temperature	-40~+70°C
Isolation endurance voltage	1000VDC		
Sampling refreshing time	450ms (every 4 channels)		

Cold end compensation	Yes	Relative humidity	5~95%, No condensation
Disconnection detection	Yes		

☆ LED Indicator

Module Status	ERROR	Power indicator
Normal working	off	on
Not power-on	off	off
Incorrect configuration or module fault	on	on
Broken thermocouple or signal over range	flash	on

☆ Range scope (note: The corresponding relation between input data and analog signal is non-linear.)

Input signal	Temperature (°C)	Corresponding input data range
J	-210~1200	-2100~12000
K	-270~1370	-2700~13700
E	-270~1000	-2700~10000
N	-270~1300	-2700~13000
T	-270~400	-2700~4000
R	-50~1768	-500~17680
S	-50~1768	-500~17680
B	0~1820	0~18200
-80~80mV	--	-8000~8000

☆ Terminal definition & wiring

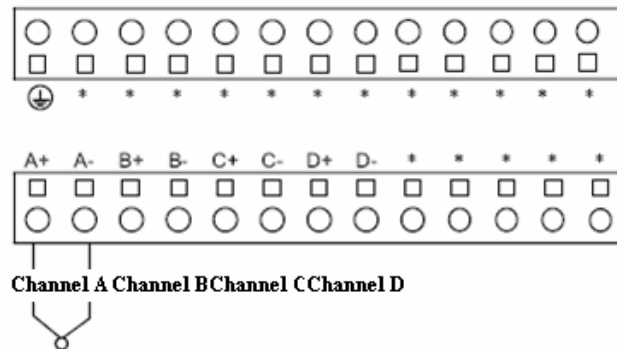

Figure 3-2-15 LM3311 Terminal Wiring

Descriptions:

- A+ and A- in the above figure terminals of an input signal channel connecting thermocouple. B+ and B- are similar.
- “⊕” means this channel connect ground protection;
- “*” means no wiring or no physical connection.

i Note: LM3311 can only connect one channel if transmitter negative terminals cannot be short connected.

☆ Software configuration

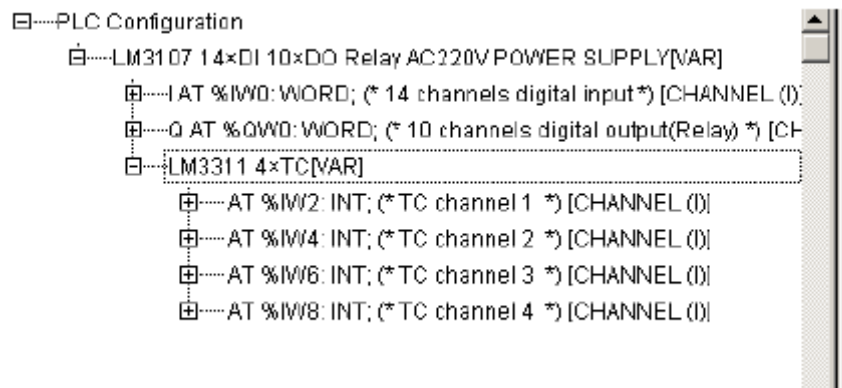

Figure3-2-16 LM3311 Software Configuration

Base parameters		Module parameters			
Index	Name	Value	Def..	Min.	Max.
1	Filter_Parameter	1	1		
2	Cold_junction_Compensation	Yes	Yes		
3	Open_Wire_Detect_Direction	Ho...	Holdi...		

Figure3-2-17 LM3311 Module Parameter Configuration

- Filter_Parameter: its value is 1, 2, 4, 8, 16 and 32.
- Filter_parameters correspond to time value of RC lowpass as shown in table 3-2-2;

- Cold_Junction_Compensation: whether compensate or not by selecting “Yes” or “No”;
- Open Wire Detect Direction: Detect the direction when wire is disconnected.
- Holding: The current value will be held when open wire occurs.
- Upscale: Positive value limit will be accessed when open wire fault occurs.
- Downscale: negative value will be accessed when open wire fault occurs.

LM3311 channel software configuration shown in Figure 3-2-18. TC Type is thermocouple type and Channel_Enable means whether the channel is available or not.

Index	Name	Value	Default	Min.	Max.
1	TC_Type	J	J		
2	Channel_Enable	Ena...	Enable		

Figure3-2-18 LM3311Channel Parameter Configuration

3.2.5 4-Channel RTD Input Module LM3312

☆ Specifications

Model		LM3312	
Input Features		Physical Features	
Input channel	4 channel	Dimension (W*H*D)	75mm(L)×90mm(W) ×70mm(H)
Input type	Cu50, Pt100	Weight	160g
Input range	Cu50 (-50-140.1℃)	Power consumption	+24VDC (Expansion bus supply) 0mA
	Cu50 (-50-150℃)		
	Pt100 (-150-157.2℃)		
	Pt100(-150-619.6℃)		
Input precision	±1℃@25℃, full range	+5VDC (Expansion bus supply) 120mA	
Temperature drift	±50ppm/℃		
Isolation mode	Isolation between field & system digital part, no isolation between channels		
Isolation endurance voltage	1000VDC		
NMMRR	Better than 70dB@50Hz	Working temperature	0~+55℃
Sampling refresh time	450ms (every four channels)	Storage temperature	-40~+70℃
Open-wire detection	Support	Relative humidity	5~95%, non-condensing

☆ LED Indicator

Module Status	ERROR	Power indicator
Normal working	off	on
Not power-on	off	off
Incorrect configuration or module fault	on	on
Open-wire or signal over range	flash	on

☆ Range scope

Input signal	Corresponding input data range
Cu50 (-50-140.1℃)	-500~1401
Cu50 (-50-150℃)	-500~1500
Pt100 (-150-157.2℃)	-1500~1572
Pt100 (-150-619.6℃)	-1500~6196

☆ Terminal definition & wiring

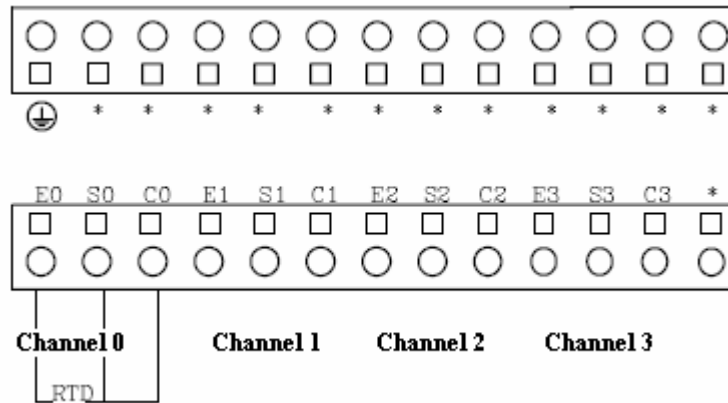

Figure 3-2-15 LM3311 Terminal Definition & Wiring

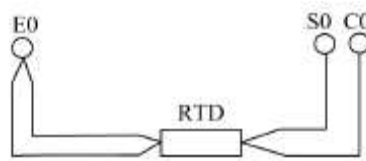

Figure 3-2-20 4-Wire RTD connection

Descriptions:

- This module can measure RTD signals of 4 channels, Wiring can be 2-wire, 3-wire, or 4-wire. In the case of 2-wire connection, please short connect S and C, bridge connect RTD between E and S. For 3-wire connection, connect one end of RTD to E, and the other end to S and C. See Figure 3-2-20 for 4-wire connection.
- In the case of no input signals and there is floating value, please short connect E, S and C to avoid error of floating ground input.
- “⊕” means this channel connect ground protection;

- “*” means no wiring or no physical connection.

☆ Software configuration

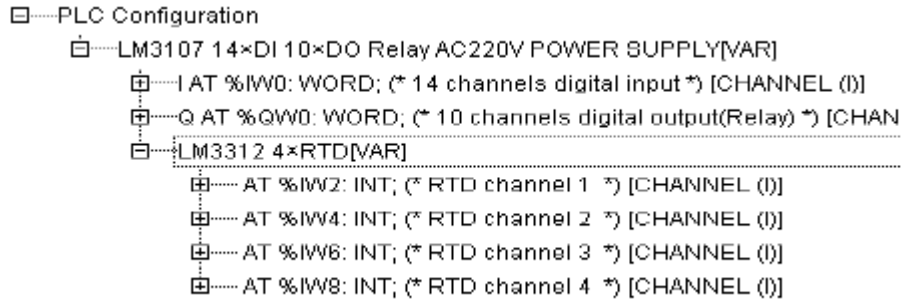

Figure 3-2-21 LM3312 Software Configuration

Index	Name	Value	Def..	Min.	Max.
1	Filter_Parameter	1	1		
2	Short_Circuit_Detect_Direction	H...	Hold...		

Figure 3-2-22 LM3312 Module Parameter Configuration

- Filter Parameter: its value is 1, 2, 4, 8, 16 and 32.
Filter parameters correspond to time constant of RC lowpass as shown in table 3-2-2;
- Short Circuit Detection: Detecting direction when short circuit fault occurs.
Holding: the current value will be held when short circuit fault occurs.
Upscale: Positive value limit will be accessed when short circuit fault occurs.
Downscale: Negative value will be accessed when short circuit fault occurs.

LM3312 channel software configuration shown in Figure 3-2-23. TC Type is thermocouple type and Channel_Enable means whether the channel is available or not.

Index	Name	Value	Default	Min.	Max.
1	RTD_...	Cu50 -50~140.1 de...	Cu50 -50~140.1 degr...		
2	Chan...	Enable	Enable		

Figure3-2-23 LM3312 Channel Parameter Configuration



Note: To unused LM3312 channel, channel parameter should be Disable, otherwise the error indicator will light up.

3.2.6 8-Channel Analog Input Module LM3313

LM3313 power supply is from expansion bus.

☆ Specifications

Model		LM3313			
Input Features		Physical Features			
Input channel	8 channels	Dimension (W*H*D)	75mm(L)×90mm(W) ×70mm(H)		
Input range	Voltage	-10~10V	Weight		170g
	Current	-20~20mA	Power consumption	+24VDC (Expansion bus supply)	35mA
Input type	Single terminal input				
Input precision (monopole)	0.1%FS@ 25°C (FS means full range, @25°C means 25°C)				
Input impedance	>1MΩ(Voltage) 500Ω(current)				
Max input current	<30mA	+5VDC (Expansion bus supply)		100mA	
Max. input voltage	<15V				
Temperature drift	±100ppm/°C				
Isolation mode	Isolation between field & system digital part, no isolation between channels	Working temperature	0~+55°C		
Isolation endurance voltage	1000VDC	Storage temperature	-40~+70°C		
Sampling refresh time	15ms (every 8 channels)	Relative humidity	5~95%, non-condensing		

☆ LED Indicator

Module Status	Power indicator
Working normally	on
Power not connected or module fault	off

☆ Range scope

Signal type	Range scope	Corresponding input data range
Voltage signal	-10V~10V	-32000~32000
Current signal	-20mA~20mA	-32000~32000

☆ Terminal definition & wiring

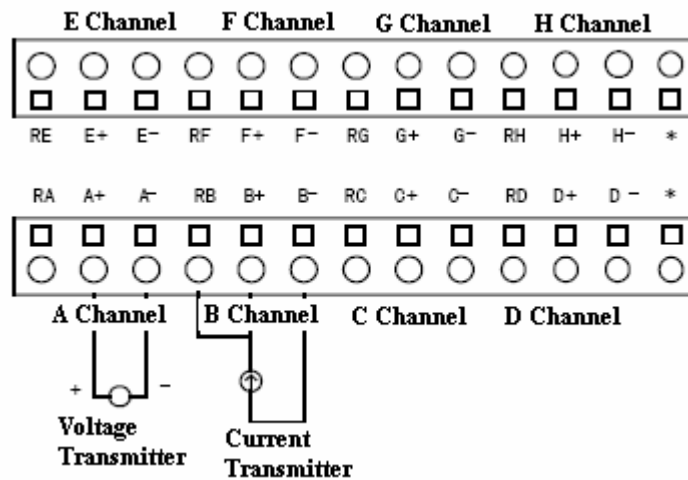



Figure 3-2-24 LM3313 Terminal Definition & Wiring

Descriptions:

- Input signal can be either voltage or current or signals. In Figure 3-2-24, when input signal is voltage signal, A+ connects the positive end of voltage transmitter, and A- connects its negative end. When input signal is current signal, please short connect RA and A+;
- 2-wire current transmitter and 4-wire current transmitter wiring method with LM3313 are the same with LM3310 and 2-wire current transmitter adopts external power supply. User can choose to use 24VDC output power of CPU module according to power capacity demand, or connect other external power, please see Figure 3-2-2. Please see Figure3-2-3 for method of 4-wire current transmitter wiring with LM3313;
- “*” means no wiring or no physical connection in this channel.

☆ Software configuration

LM3313 software configuration is similar to LM3310. Please refer to 3.2.1 section in LM3310 software configuration section.

 Note: LM3313 adopts Single-Ended Inputs, can only connect one channel if transmitter negative terminals can not be short connected.

3.2.7 8 Channel Thermo Sensitive Input Module LM3314

LM3314 requires that R value of NTC is 10K at 25°C to guarantee the measuring precision.

☆ Specifications

Model		LM3314			
Input Features		Physical Features			
Input channel	8 channels	Dimension (W*H*D)		75mm(L)×90mm(W) ×70mm(H)	
		Weight		160g	
NTC type	R = 10K at 25°C; B optional	Power	+24VDC (Expansion bus supply)	0mA	
			consumption	+24VDC (External supply)	40mA
				+5VDC (Expansion bus supply)	100mA
		Temperature resolution	0.1°C		
		Temperature drift	±100ppm/°C		
Open-wire detection	Support				
Isolation mode	Isolation between field & system digital part, no isolation between channels	Working temperature		0~+55°C	
Isolation endurance voltage	1500VAC				
NMMRR	Better than 60dB@50Hz	Storage temperature		-40~+70°C	
Sampling refresh time	1s	Relative humidity		5~95%, no condensation	

(every 8 channels)			
--------------------	--	--	--

☆ LED Indicator

Module Status	ERROR	Power indicator
Working normally	off	on
Power not connected	off	off
Incorrect configuration or module fault	on	on
Open-wire or signal over range	flash	on

☆ Range scope

Measuring temperature signal scope	Corresponding input data range
-20℃ ~ 100℃	-200 ~ 1000

☆ Terminal definition & wiring

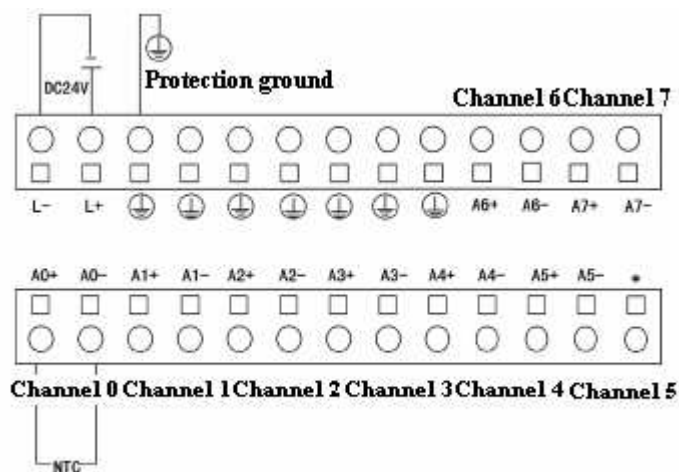

Figure 3-2-25 LM3314 Terminal Definition & Wiring

Descriptions:

- L+ and L- on the left side of the upper level terminals are the positive and negative ends of 24VDC power supply for module respectively;
- This module can measure NTC signals of 8 channels, see Figure 3-2-25, A0+ and A0- are input terminals of NTC channel 0 respectively, the rest channels are similar;

- “⊕” means this channel connect ground protection;
- “*” means no wiring or no physical connection.

☆ Software configuration

See Figure 3-2-26 for LM3314 software configuration.

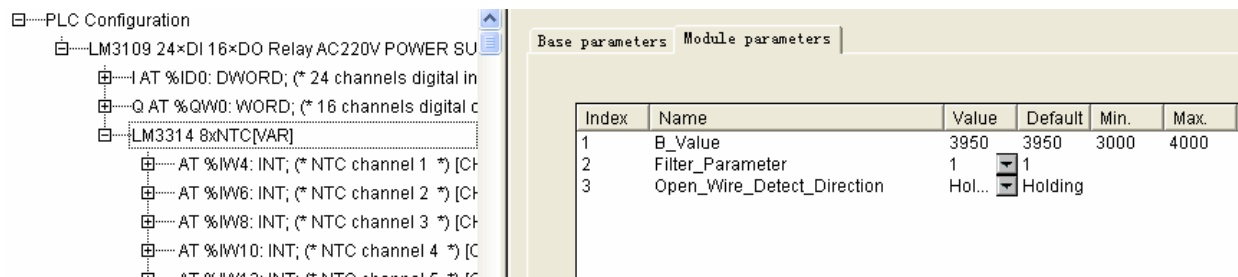

Figure 3-2-26 LM3314 Software Configuration

- B Value: The minimal value is 3000, the maximal value is 4000 and default value is 3950.
- Filter Parameter: Its value can be 1, 2, 4, 8, 16 and 32.
The filter parameters correspond to the time constant of RC lowpass as shown in table 3-2-2.
- Open Wire Detect Direction: Detect direction when open circuit occurs;
Holding: The current value will be held when open circuit fault occurs;
Upscale: The positive limit value will be read when open circuit fault occurs;
Downscale: Then negative limit value will be read when open circuit fault occurs.

3.2.8 2-Channel Analog output Module LM3320

☆ Specifications

Model		LM3320			
Output Features			Physical Features		
Output channel	2 channels		Dimension (W*H*D)	75mm(L)×90mm(W) ×70mm(H)	
Output range	Voltage	0~10V	Weight	<200g	
	Current	0~20mA	Power consumption	+24VDC(Expansion bus supply)	0mA
Precision(0~+55℃)	2%FS (FS means full range, @25℃ means at 25℃)			+24VDC(External supply)	80mA
Typical precision	0.5%FS@25℃ (FS means full range, 25℃ means at 25℃)			+5VDC(Expansion bus supply)	60mA

Setup time	Voltage output	$\leq 10\mu\text{s}$	Working temperature	0~+55°C
	Current output	$\leq 10\mu\text{s}$		
Drive	Voltage	Min.2000Ω	Storage temperature	-40~+70°C
	Current	Max.600Ω		
Isolation mode		Optical-coupler isolation	Relative humidity	5~95%, no condensation
Isolation endurance voltage		1500VAC		

☆ LED Indicator

Module Status	Power indicator
Working normally	on
Not power-on or module fault	off

☆ Signal Type & Range of Output Channel

Signal Mode	Range	Corresponding input data range	
		Decimal	Hex
Voltage signal	0~10V	0~1638	0x00~0x666
Current signal	0~20mA	0~3277	0x00~0xCCD

☆ Terminal definition & wiring

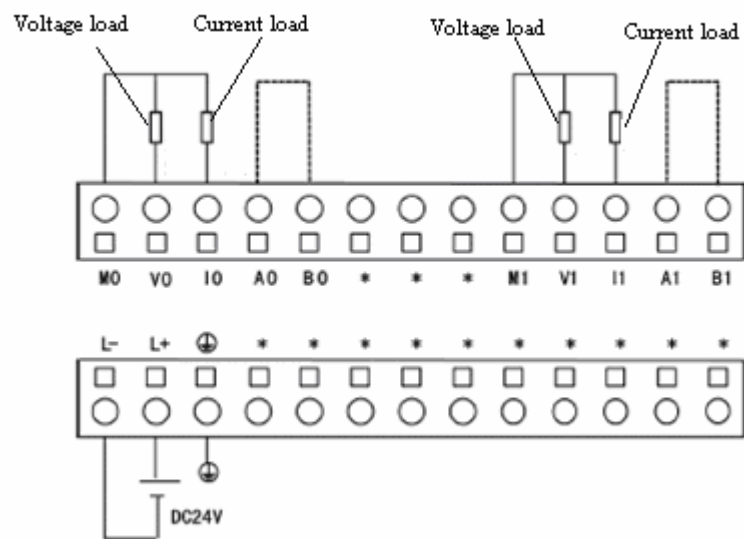

Figure 3-2-27 LM3320 Terminal Definition & Wiring

Descriptions:

- L+ and L- are the positive and negative ends of external 24VDC power supply respectively.
- M0 and M1 are common ends.
- V0 and V1 are output ends of external voltage load.
- I0 and I1 are output ends of external current load.
- When I0 end connects external current load, A0 and B0 should be short connected. When I1 end connects external current load, A1 and B1 should be short connected.
- “⊕” means this channel connect ground protection.
- “*” means no wiring or no physical connection.

☆ Equivalent Circuit

Output channel (AO) (voltage output signal) equivalent circuit is shown in Figure 3-2-28.

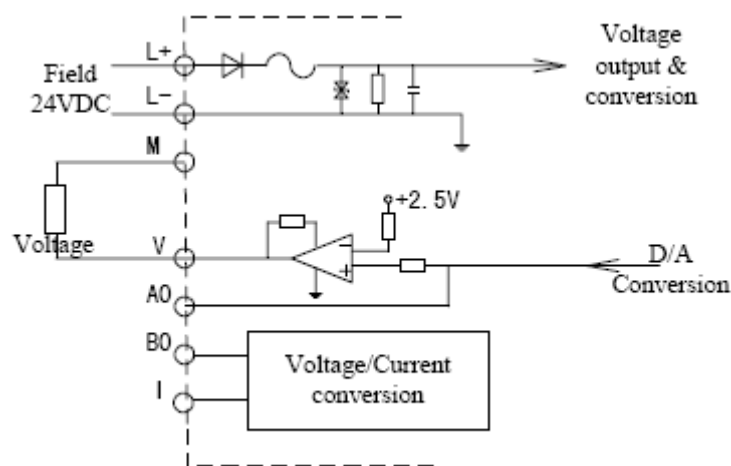

Figure 3-2-28 LM3320 Voltage Output Channel Equivalent Circuit

Output channel (AO) (current output signal) equivalent circuit is shown in Figure 3-2-29.

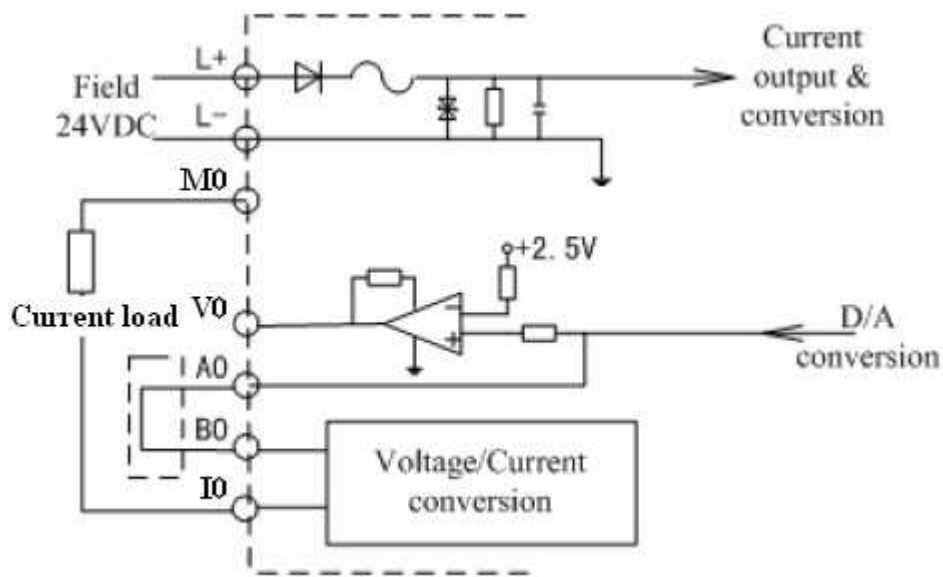

Figure 3-2-29 LM3320 Current Output Channel Equivalent Circuit

☆ Software configuration

LM3314 software configuration is shown in Figure 3-2-30. XFactor is output signal type selection.

Index	Name	Value	Default
1	XFactor	0-20mA	0-20mA

Figure 3-2-30 LM3320 Channel Parameter Configuration

3.2.9 4-Channel Analog Input/1-Channel Analog Output Module

LM3330

☆ Specifications

Model		LM3330				
Input Features			Output Features			
Input channel		4 channels		Output channel		1 channel
Input range	Voltage	0~10V		Output range	Voltage	0~10V
	Current	0~20mA/4~20mA			Current	0~20mA
Precision		0.5%FS@25°C (FS means full range, @25°C means at 25°C)		Precision		0.5%FS@25°C (FS means full range, @25°C means at 25°C)
Digital analog conversion time		<200μs		Temperature drift		±100ppm/°C
Input type		Single input		Setup time	Voltage output	<100μs
Temperature drift		±100ppm/°C			Current output	<100μs
Sampling refresh time		6ms				
Input impedance		1 MΩ (Voltage input)		Drive	Voltage	Min. 2KΩ
		250Ω (Current input)			Current	Max. 600Ω
Isolation mode		No isolation between field & system digital part, no isolation between channels		Isolation mode		No isolation between field & system digital part, no isolation between channels
Physical Features						
Dimension (W*H*D)		75mm(L)×90mm(W) × 70mm(H)		Power consumption	+24VDC(Expansion bus supply)	30mA
Weight		200g			+24VDC(External supply)	0
Working temperature		0~+55°C			+5VDC(Expansion bus supply)	50mA
Storage temperature		-40~+70°C		Relative humidity		5~95%, no-condensing

☆ LED Indicator

Module Status	Power indicator
Working normally	on
Not power-on or module fault	off

☆ Signal Type & Range of Channel

Analog input			
Input signal	Range	Corresponding input data range	
		Decimal	Hex
Voltage signal	0~10V	0~65535	0x0000~0xFFFF
Current signal	0~20mA	0~65535	0x0000~0xFFFF
Current signal	4~20mA	0~65535	0x0000~0xFFFF
Analog output			
Output signal	Range	Corresponding input data range	
		Decimal	Hex
Voltage signal	0~10V	0~65535	0x0000~0xFFFF
Current signal	0~20mA	0~65535	0x0000~0xFFFF

☆ Terminal definition & wiring

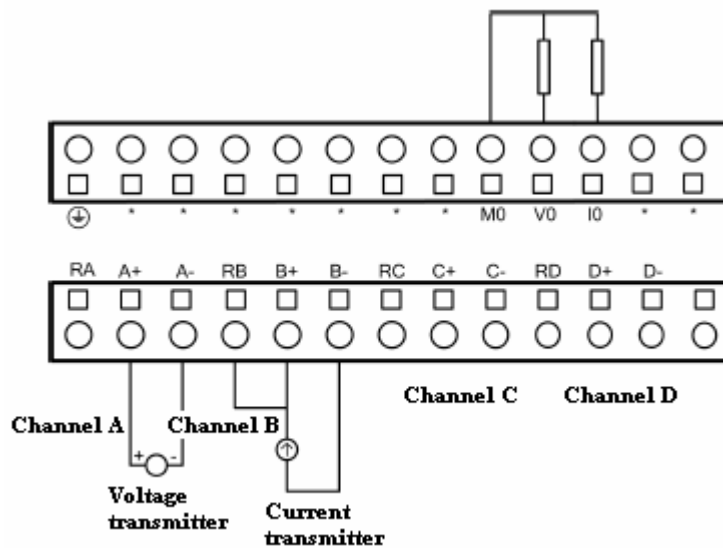



Figure 3-2-31 LM3330 Terminal Definition & Wiring

Descriptions:

- The upper level terminals are signal output channels, can connect voltage load and also current load.
- The lower level terminals are signal input channels, correspond to four (A, B, C, D) input channels, input signal can be voltage and also current. For example, when voltage

signal was inputted, A+ connects the positive end of voltage transmitter, A- connects the its negative end; when current signal was inputted, please short connect RA and A+ and then connect the positive end of current transmitter, connect A- with the negative end of current transmitter.

- “” means this channel connect ground protection, provide static release channel for internal analog process circuit;
- “*” means no wiring or no physical connection.

☆ Equivalent Circuit

- Input channel (AI) equivalent circuit of LM3330 is the same as LM3310A, please refer to Figure 3-2-10;
- Output channel (AO) equivalent circuit of LM3330 is the same as LM3320, please refer to Figure 3-2-28 and Figure 3-2-29;

3.3 Special Function Expansion Modules

3.3.1 Profibus-DP Slave Station Module LM3401

LM Series connect to Profibus-DP network with LM3401 as Profibus-DP slave station as shown in Figure 3-3-1.

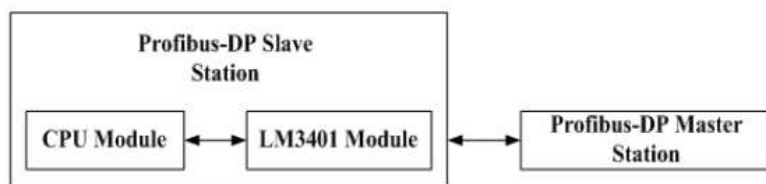

Figure 3-3-1 LM3401 Network Function

☆ Specifications

Model		LM3330	
Communication Function		Physical features	
Number of Communication Port	1	Dimensions	75mm(L) × 90mm(W) × 70mm(H)
Interface type	9 pins D type socket/	Weight	160g

	wiring terminal		
Isolation endurance voltage	1500VAC	Power consumption	+24VDC (External bus supply) 20mA
PROFIBUS-DP baud rate	9.6,19.2,45.45,93.75,187.5,500kbps and 1,1.5,3,6,12Mbps (auto adaptive)		
Station address setup	0~126 (set by dial switch)		+5VDC (Expansion bus supply) 120mA
Input/output size	Max. 64 byte each		
Max. station for each section	32	Working temperature	0~+55℃
Max. station for each network	126	Storage temperature	-40~+70℃
Isolation mode	Optical-coupler isolation	Relative humidity	5~95%, No condensation

☆ LED Indicator

Light	OFF	Green ON	Green Flash	Red ON
RUN	Not power-on or damaged	Module working normally	Establishing communication	—
COMM	No communication	Communication status	—	—
ERROR	No error	—	—	Communication error

☆ Terminal Definition & Wiring

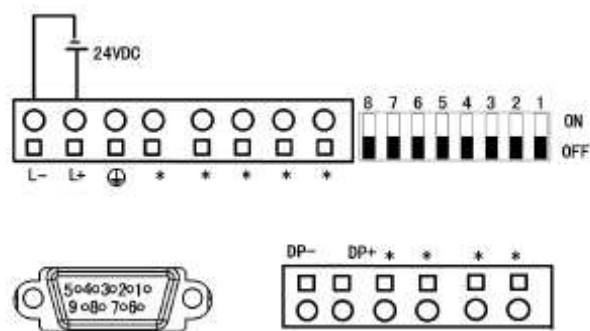

Figure 3-3-2 LM3401 Terminal Definition & Wiring

Descriptions:

- L+ and L- in the above figure stands for the positive end and negative end of external 24VDC power supply.
- DP+ and DP- in the above figure connect 3(B) and 8(A) pin of DB9 linker inside circuit board.
- 8-bit dial switch is used to set up slave station address, ON=0, OFF=1, the binary value relationship between switch status and station address is shown in Figure 3-3-3.

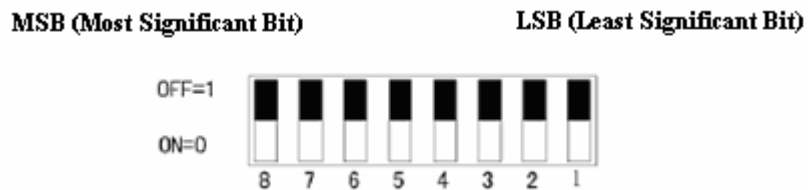

Figure 3-3-3 Binary Value Relationship between Switch Status & Station Address

See Figure 3-3-4 for example.

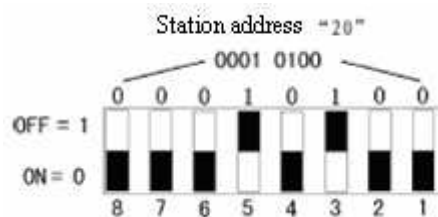

Figure 3-3-4 Slave Station Address Setting as 20 (decimal)

- “*” means no wiring or no physical connection.

☆ DB9 Linker Signal Definition

See Table 3-3-1 for DB9 linker signal definition and descriptions.

Table 3-3-1 DB9 Linker Signal Definition

Linker pin No.	Definition	Linker pin No.	Definition
1	Shielding, connect linker shell	6	VP (+5V,90mA)
2	—	7	—
3	B (RxD/TxD+)	8	A (RxD/TxD-)
4	CNTR-P Requesting sending signal RTS (TTL electrical level)	9	—
5	DGND, +5V ground		

☆ Relationship between Baud Rate & Cable Length

Table3-3-2 Relationship between Baud Rate & Cable Length

Baud Rate	Cable Length
≤93.75kbps	<1,200m

187.5kbps	<1,000m
500kbps	<400m
1.5Mbps	<200m
3~12Mbps	<100m

☆ Software configuration

See Figure 3-3-5 for LM3401 software parameter configuration. InputDataLen_Byte and OutputDataLen_Byte mean input-data-section size and output-data-section size respectively; the maximum is 64 byte.

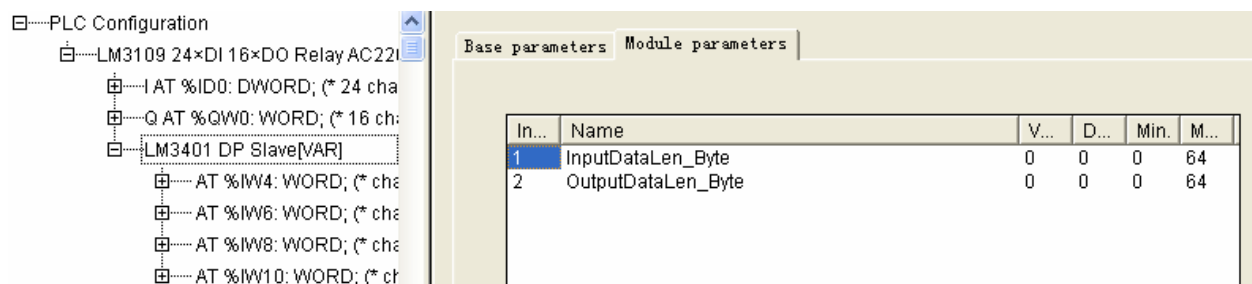

Figure 3-3-5 LM3401 Software Configuration

- ☆ The way of getting gsd file when configuration in master station
 - From software install CD >> Added file >> get HSLM3401.gsd.

i When DP module is connected as expansion module, it should be placed at the first position on the right side of CPU module.

3.3.2 Ethernet Interface Module LM3403

LM3403 is Ethernet expansion module, through LM3403 module, LM Series PLC can link to local area network as MODBUS TCP slave station.

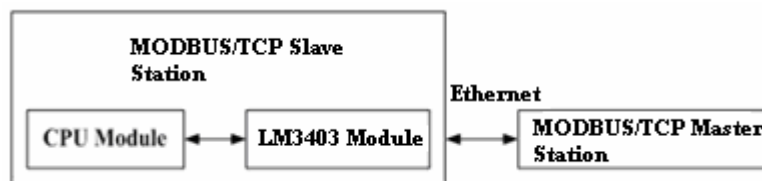

Figure 3-3-6 LM3403 Network Function

☆ Specifications

Model		LM3403	
Communication Function		Physical features	
Number of Communication Port	1 (can only communicate with one MODBUS TCP master station at one time)	Dimensions	75mm(L)×90mm(W)×70mm(H)
Interface type	Ethernet (RJ45)	Weight	160g
Protocol type	MODBUS TCP slave station	Power consumption	0mA
Configure content needed	IP address(leave factory default value is 172.20.45.160), subnet mask, gateway IP, read & write data length (note: MAC_Address doesn't need configuration)		
Communication rate	10Mbps	+5VDC(Expansion bus supply)	80mA
Size of input & output section	Max. 200 byte each	Working temperature	0~+55℃
Max. number of station for each network	Lie on configuration software	Storage temperature	-40~+70℃
		Relative humidity	5~95%, non-condensing

☆ LED Indicator

Light(status)	OFF	Green ON	Green Flash	Red ON
RUN	Not power-on or damaged	Module working normally	—	—
LINK	Ethernet connection not established	Ethernet connection established	—	—
RX/TX	No data receive & send	—	Data receive & send	—
ERROR	No error	—	—	Communication error

☆ Terminal Definition & Wiring

- This module has no practical physical connection
- RJ45 port connects Ethernet.

☆ Software configuration

See Figure 3-3-7 for LM3403 software configuration. Thereinto, IP_Address, Subnet_Mask, Gateway_Address are IP configuration, subnet mask and gateway. MAC_Address doesn't need configuration. ReadDataLen_Byte and WriteDataLen are size of configuration input section and output section, the maximum is 200 byte.

Ind...	Name	Val...	De...	Min.	Max.
1	IP_Address				
2	Subnet_Mask				
3	Gateway_Address				
4	MAC_Address				
5	ReadDataLen_Byte	0	0	0	200
6	WriteDataLen_Byte	0	0	0	200

Figure 3-3-7 LM3403 Software Configuration

☆ MODBUS TCP function describe

Function code	Name	Function(for master station)
01	Read digital output status	Get current status of a series of digital output
02	Read digital input status	Get current status of a series of digital input
03	Read analog output status	Get current status of a series of analog output
04	Read analog input status	Get current status of a series of analog input
05	Force single channel digital output	Force setting one digital output value
06	Force single channel analog output	Force setting one analog output value
15	Force multi channel digital output	Force setting multi digital output value
16	Force multi analog output	Force setting multi analog output value



When Ethernet module was connected as expansion module, it should be placed at the first position on the right side of CPU module.

Chapter 4 Installation

4.1 Guidance Principle

For more effective and safe use of G3 micro PLC, the following installation guidance will show you how to properly install system components, and to ensure the installation agreeing to the electromagnetic compatibility.

4.1.1 Ventilation

As all electrical equipment will be working continuously under fierce environment with peak load and high temperature, equipment life span will be shortened. Ventilation will be taken into serious consideration.

G3 micro PLC adopts natural convection ventilation and requires special location and space. Please locate the PLC modules as shown in Figure 4-1-1 for good ventilation for all installation modes.

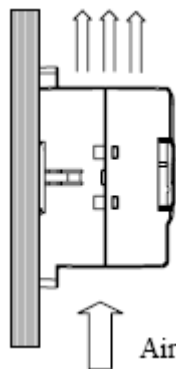

Figure 4-1-1 Recommended Ventilation

To avoid malfunction caused by poor ventilation, please do not install the PLC as Figure 4-1-2.

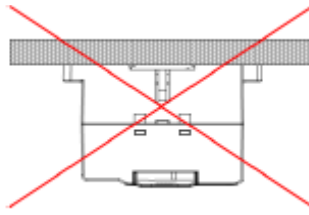

Figure 4-1-2 Avoid Ventilation

At the same time, there should be at least 50mm space above and below each module for regular ventilation. In the case of front baffle, the depth between baffles must be kept at 100mm as shown in Figure 2-1-3.

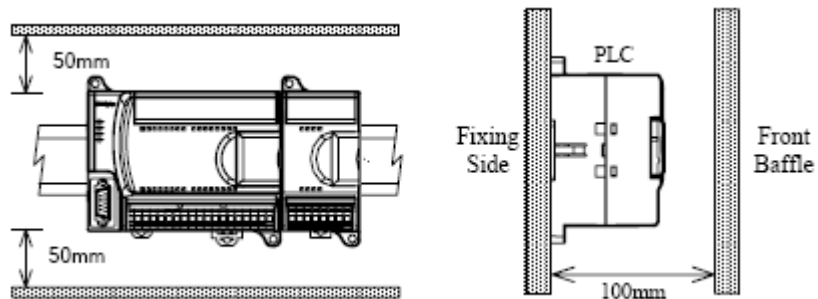

Figure 4-1-3 PLC Space Requirements

Please also note that there must be enough space for expansion cable and communication cable.

4.1.2 Cable Location Properly

The following are general principles of cable installation and field wiring. For more details please refer to the related chapters as different modules require different wiring.

- G3 series PLC adopts AWG28-12 (0.321~2.053mm) cables, there should use correct wire;
- Divide the cables into different types according to their functions and assign them with serial numbers;
- Avoid installing input and output cable in the same cable trough ;
- Input and output signal cables must be shielded;
- Separate the AC cables and high-power DC cables from the low power signal cables;
- Avoid installing big-current cables and signal or data cables in the same trough;

4.2 Electrical Safety

When G3 micro PLC is running, for the safety of operators and equipment, a safety loop can be created independently from the PLC system, such as redundant protection, power overload protection and emergency shutdown to avoid emergency condition occurs.

4.2.1 Restraining loop

It is recommended to add restrain loop in inductive load to limit voltage instant rise when power off. The following is recommended:

☆ DC Transistor Protection

For G3 micro PLC DC transistor output, for instructive load with large induction or frequent on-off, external flywheel diode can be used to avoid penetration of internal transistor, Figure 4-2-1 and Figure 4-2-2 show the typical applications of DC transistor output protection.

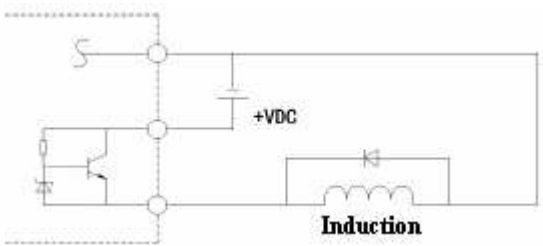

Figure 4-2-1 DC Transistor Output Normal Diode Protection

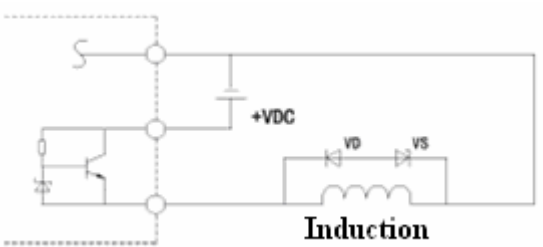

Figure 4-2-2 DC Transistor Output Regulated Diode Protection

☆ DC Transistor Protection

Apply resistance / capacitance network in LV(DC30V)DC relay circuit, and cross connect with load to create a relay-driven and DC load DC

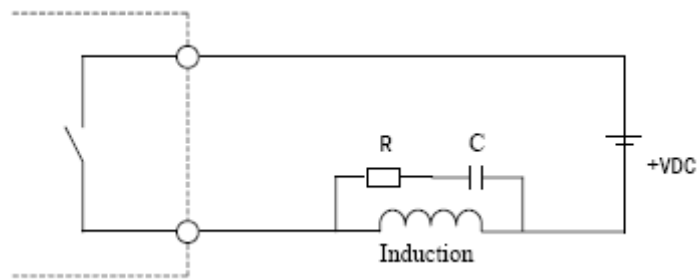

Figure 4-2-3 DC Relay Protection

☆ AC Relay Protection

When AC Relay is used to control 220VAC load, it is recommended to cross connect resistance/capacitance network in AC relay for protection as shown in Figure 4-2-4.

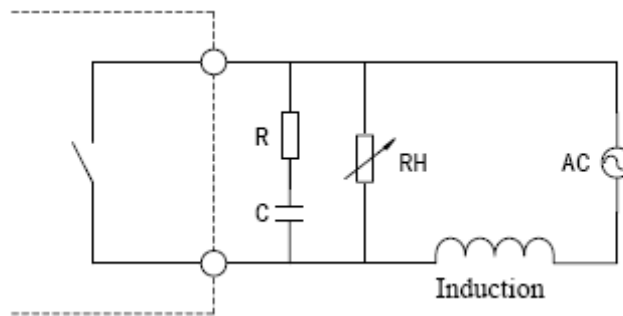

Figure 4-2-4 AC Relay Protection

4.2.2 Emergency Shutdown

To avoid casualties or property loss, a fast power shutdown or switch as well as clear signs of “Emergency Shutdown” must be available.

4.3 Installation & Disassembly

During the installation or disassembly of G3 series micro PLC, failure to effectively cut off the power will incur casualties or equipment damage. Therefore, always make sure all power is shutdown before installing or disassembling PLC modules and related equipment.

4.3.1 Installation Mode

G3 micro PLC offers two installation modes for user selection. In different engineering environments, it can be installed either on flat panel or on DIN standard rail as shown in Figure 4-3-1.

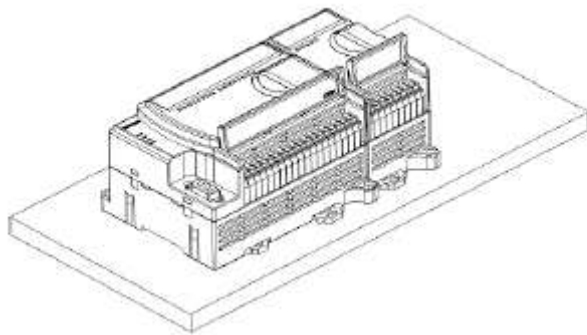

Panel Installation

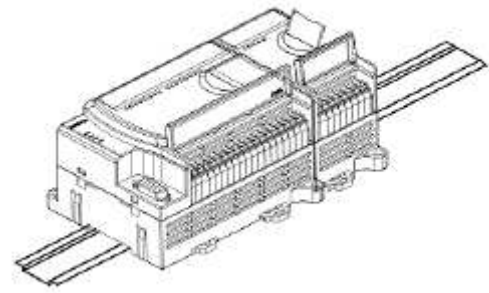

DIN Rail Installation

Figure 4-3-1 Installation Modes

1、 Panel Installation

☆ Installation

- Setup holes on the panel according to module size and installation location hole;
- Fix CPU on the panel with bolts;
- Locate and fasten the expansion module, if any, side by side in turn on the side of the adjacent module;
- Connect the expansion cable to the linker on the right side of the adjacent module in the correct direction;
- Connect signal cables.

Installation process is shown in Figure 4-3-2.

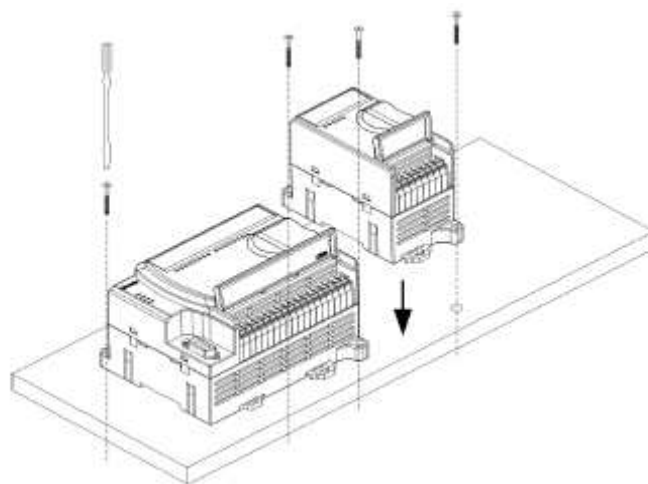

Figure 4-3-2 Panel Installation Mode

☆ Disassembly

- Disassemble all signal cables;
- Disassemble cables that connect adjacent modules;
- Loosen the fixed bolts and take off modules in turn.

Disassemble process is shown in Figure 4-3-3.

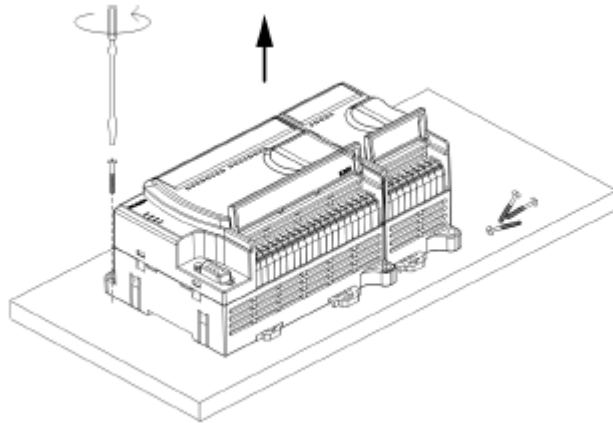

Figure 4-3-3 Module Disassembly

2、 Rail Installation

- ☆ Standard DIN rail and DIN rail pin

Install G3 micro PLC on standard 35mm DIN rail, and slide PLC module horizontally along the rail. Figure 4-3-4 shows the sizes of two common DIN rails, Figure 4-3-5 shows the DIN rail pin.

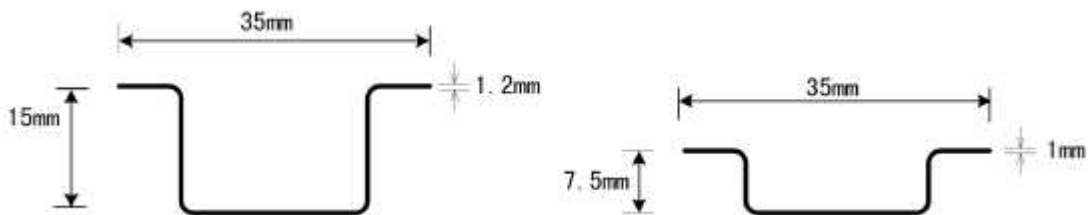

Figure 4-3-4 Standard 35mm DIN

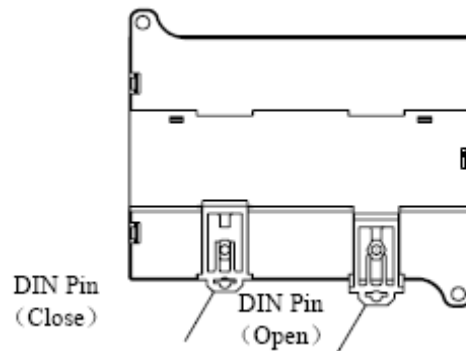

Figure 4-3-5 Rail Pin

☆ Installation

- Loosen the DIN pin on the bottom of CPU module, and place the module on the DIN rail;
- Close DIN pin and make CPU module fixed compactly with the rail;
- Fasten the expansion modules, if any, side by side on the rail;
- Connect the cable of the expansion module to the linker on the right side of the adjacent module, and ensure correct cable direction;
- Connect the signal cables.

The installation process is shown in Figure 4-3-6.

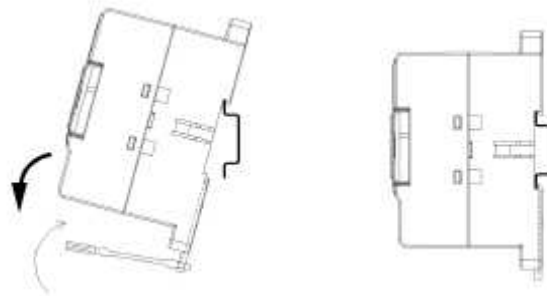

Figure 4-3-6 Rail Installation

☆ Disassembly

- Disassemble all cables;
- Disassemble the cables connecting adjacent modules;
- Loosen DIN pin and remove the modules in turn.

Disassembly process is shown in Figure 4-3-7.

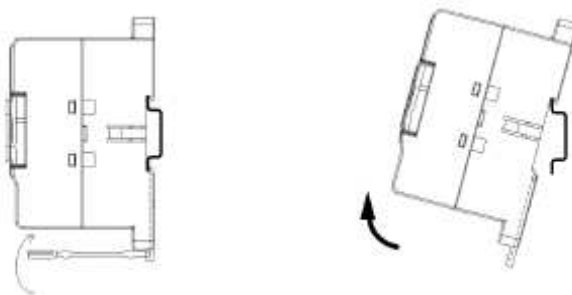

Figure 4-3-7 Disassemble Module from Rail

4.3.2 Connect Expansion Cable

When connecting modules, expansion cable plug must be in the same direction as the electrical outlet notch of the expansion interface of adjacent module, as shown in Figure 4-3-8.

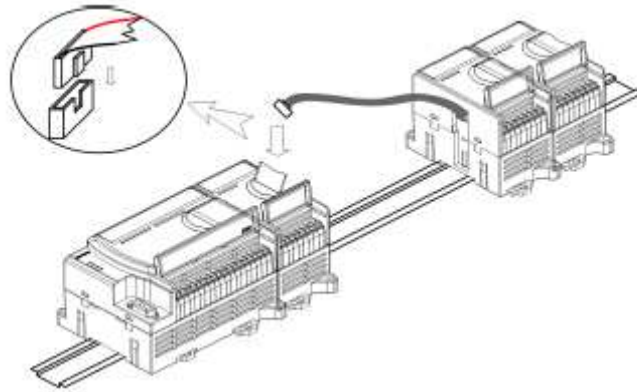

Figure 4-3-8 Connection of Expansion Cables between Modules

Last but not least, if false modules are replaced during maintenance, error may incur in the control program. False replacement of expansion modules and cables will result in serious consequences. Therefore, be sure to replace the modules with the same models correctly and locate them properly.

4.3.2 Terminal Wiring

LM series PLC adopts patent wiring terminals of WAGO Company in Germany, its wiring is hard and easy to wire and disassemble and it could save seventy-five percent of time to wire. As the WAGO connector adopts advanced spring holding and wiring technology, it has used the best electrical insulating material, electric material, have extrusive features such as high reliability, high safety, high efficiency, anti-vibration and lower maintenance costs.

During wiring process, please peel insulated scarfskin with definite length first, then plug screwdriver into adjacent rectangular hole with terminal identifier, unplug the screwdriver after plugging the peeled lead into unlocked circle hole(namely “plug spring holding connector”) and the stainless angle reed could exert needed pressure to impact wire.



Figure 4-3-9 Terminal Wiring

There will be common end in field contact wiring, according to the different location of common end in circuit structure, the DI circuit can be divided into two architectures:

Sourcing type DI: current flows from photoelectric coupler to switch, the other end of many switches are short connected together with power ground (as shown in Figure 4-3-10), output current is flowed to contacts for photoelectric coupler of DI devices, so it is named Sourcing type DI.

Sinking type DI: one end of many switches are short connected to the positive end of sensor power, current flows from switch to ground through photoelectric coupler (as shown in Figure 4-3-11), it absorbs current from contacts for photoelectric coupler of DI, so it is also named Sinking type DI .

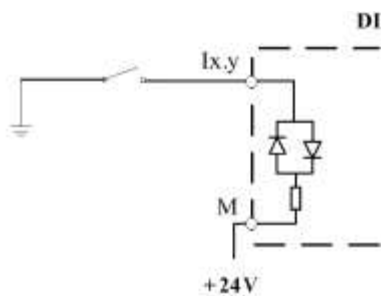

Figure 4-3-10 Sourcing type DI

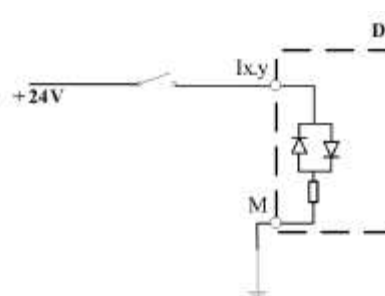

Figure 4-3-11 Sinking type DI

In general, two factors will be considered when selecting Sourcing DI or Sinking DI on earth:

(1) During debugging, for Sinking type DI, if the other end of contact is wired to the power ground of sensor with mistake, it may cause short circuit to burn fuse. For Sourcing type DI there is no problem like this because power first passes through photoelectric coupler and current limit resistance.

(2) When need to connect output of DO module with DI module, there will be two structures of Sinking and Sourcing, so when DO is Sinking type structure it is required that DI is Sourcing type structure; when DO is Sourcing type, it is required that DI is Sinking structure.

4.4 Dimension structure

The width and height of all kinds of modules of LM series micro integrated PLC is the same, the difference is only length.

Figure 4-4-1 shows the dimension and structure of LM series micro integrated PLC module.

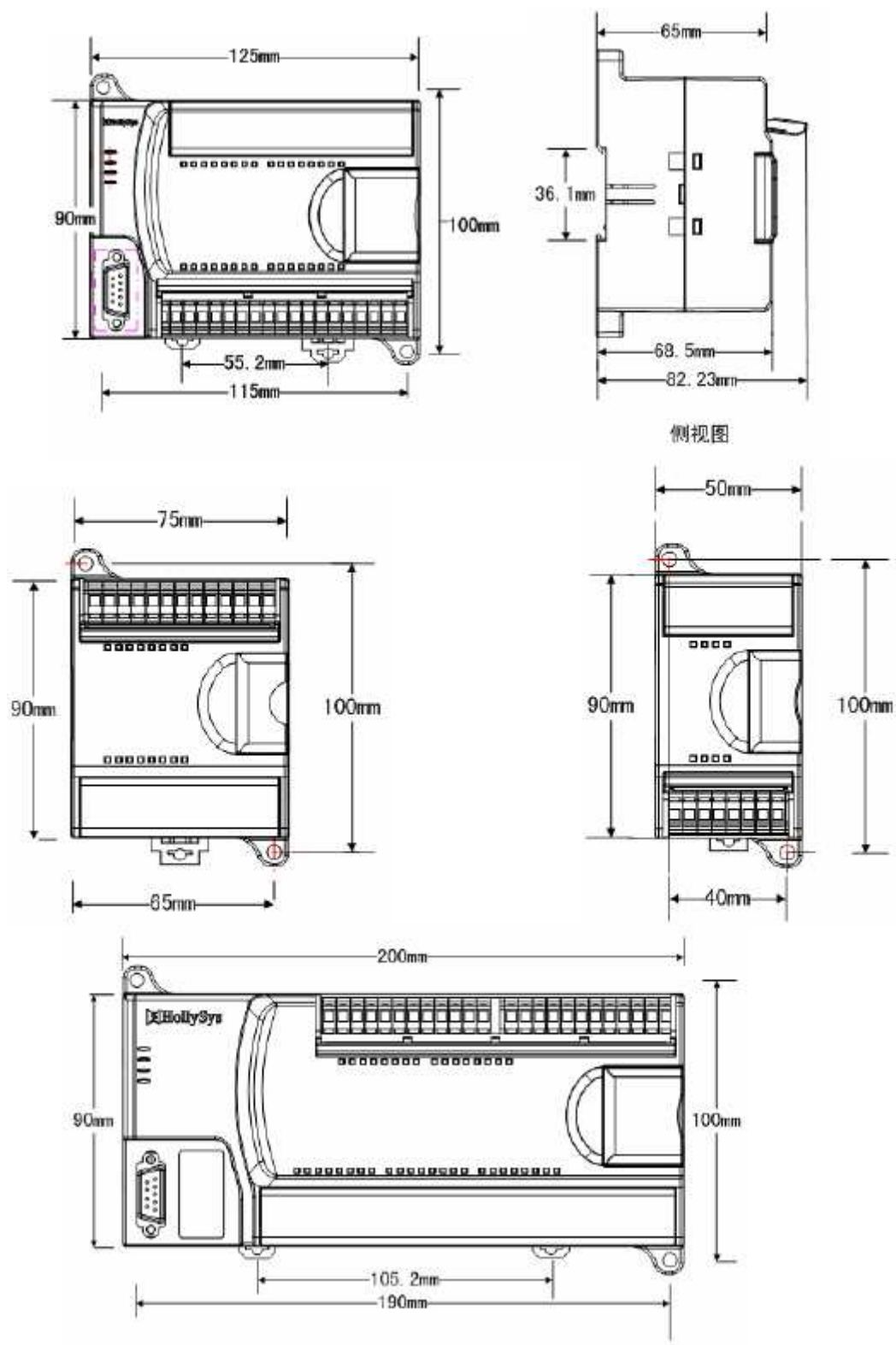

Figure 4-4-1 LM Series Micro Integrated PLC Module Structure and Dimension

Appendix

A、LM Series Micro PLC Products Oder List

Module type	Model	Dimension (L)×(W) ×(H)	Specifications
CPU module	LM3104	125mm×90mm×70mm	CPU, DC24V, 14 points I/O; DI 8×DC24V, DO 6×Transistor output
	LM3105	125mm×90mm×70mm	CPU, AC220V, 14 points I/O, DI 8×24VDC, DO 6×relay output
	LM3106	125mm×90mm×70mm	CPU, DC24V, 24 points I/O, DI 14×24VDC, DO 10×transistor output
	LM3106A	125mm×90mm×70mm	CPU, DC24V, 24 points I/O, DI 14×24VDC, DO 10×transistor output Special module for motor control
	LM3107	125mm×90mm×70mm	CPU, AC220V, 24 points I/O, DI 14×24VDC, DO 10×relay output
	LM3108	200mm×90mm×70mm	CPU, DC24V, 40 points I/O, DI 24×DC24V, DO 16×relay output
	LM3109	200mm×90mm×70mm	CPU, DC24V, 40 points I/O, DI 24×DC24V, DO 16×relay output
Digital expansion I/O module	LM3210	50mm×90mm×70mm	8 channel DI module 8×DC24V input
	LM3211	75mm×90mm×70mm	8 channel DI module 8×AC220V input
	LM3212	75mm×90mm×70mm	16 channel DI module 16×DC24V input
	LM3220	50mm×90mm×70mm	8 channel DI module 8×DC24V transistor output
	LM3221	75mm×90mm×70mm	16 channel DO module 16×DC24V transistor output
	LM3222	50mm×90mm×70mm	8 channel DO module 8×relay output
	LM3223	75mm×90mm×70mm	16 channel DO module 16×relay output
	LM3230	50mm×90mm×70mm	4 channel digital input/4 channel transistor output, DI 4×DC24V+DO 4×DC24V transistor output
	LM3231		4 channel digital input/4 channel

Analog expansion I/O module		50mm×90mm×70mm	relay output module, DI 4×DC24V+DO 4×relay output
	LM3310	75mm×90mm×70mm	4 channel analog input (4~20mA/0~20mA/0~10V optional)
	LM3310A	75mm×90mm×70mm	4 channel analog input (4~20mA/0~20mA/0~10V optional)
	LM3310B	75mm×90mm×70mm	4 channel analog input (4~20mA/0~20mA/0~10V optional)
	LM3311	75mm×90mm×70mm	4 channel thermocouple input (J、K、E、N、T、R、S、B type thermocouple, ±80Mv)
	LM3312	75mm×90mm×70mm	4 channel RTD input (Cu50(-50-140.1°C),Cu50(-50-150°C),Pt100(-150-157.2°C),Pt100(-150-619.6°C))
	LM3313	75mm×90mm×70mm	8 channel analog input (-10V~10V,-20mA~20mA)
	LM3314	75mm×90mm×70mm	8 channel NTC input (R25°C is 10K, NTC of optional B value)
	LM3320	75mm×90mm×70mm	2 channel analog output (0~20mA/0~10V optional)
	LM3330	75mm×90mm×70mm	4 channel analog input (4~20mA/0~20mA/0~10V optional) 1 channel analog output (0~20mA/0~10V optional)
Expansion Function Module	LM3401	75mm×90mm×70mm	Profibus-DP slave module
	LM3403	75mm×90mm×70mm	Ethernet module
Attachment & Software	LS3600-version No.		Programming software PowerPro
	LA3800	2 m	Programming cable
	LD3000		Hardware manual
	LD3001		Software manual
	LD3002		Instruction manual

B、LM Series Micro PLC General Technology Specification

Environment condition	Transportation and storage	Temperature	Use temperature: 0~+55℃, storage temperature:-40~+70℃
		Humidity	5~95%, no-condensing.
		Incline and overturn	Standard: GB/T2423.7-1995, 50mm fall down four times, no package
		Free fall	Standard: GB/T2423.8-1995, 1m five times, transportation and package.
	Working condition	Libration	Standard: GB/T2423.10-1995 peak-peak value 0.3mm, 1G/Rail installation, frequency 10~150HZM, three times each axes, double frequency range/minute
		Strike	Standard: GB/T2423.5-1995 15G, 11ms, six times each axes.
Protection degree		Mechanical protection IP20	
Electromagnetic compatibility	Shell	Static discharge	Standard: IEC61000-4-2, grade: 2/3, contact discharge 4Kv, air discharge 8kV.
		Operating frequency magnetic field	Standard: IEC61000-4-8, grade: 4, steady and continuous magnetic field testing magnetic intension: 30A/m.
	AC power	Voltage drop or interruption	Standard: IEC61000-4-11, grade: 3, interrupt 0.5 period wave.
		Fast and transient pulse group	Standard: IEC61000-4-4, grade: 3, 2Kv
		Surge	Standard: IEC61000-4-5, grade: 2/3, wire to wire 1kV, wire to ground 2 kV
	I/O signal or control signal	Radio-frequency electromagnetic field radiation anti-disturbance test	Standard: IEC61000-4-3, grade: 3, 80MHz~1GHz 10V/m, 80% modulation at 1kHz.
		Fast and transient pulse group	Standard: IEC61000-4-6, grade: 3, 1kV.
		Conduction annoy of radio-frequency field induction	Standard: IEC61000-4-6, grade: 3, 10V, 0.15~80MHz, 80% modulation at 1KHz.
	Electromagnetic radiation	Measurement of radiation disturbance	Standard: IEC61131-2, 30~230MHz, 10m quasi-peak value is less than 40dB(μ V/m) 230~1000MHz, 10m quasi-peak value less than 47dB(μ V/m)
Measurement of conduction disturbance		Standard: IEC61131-2, 0.15~0.5MHz, quasi-peak value is less than 79dB(μV), the average value is less than 66dB(μV); 0.5~30MHz, quasi-peak is less than 73dB(μV),the average value is less than 60Db(μV)	
Limit value of		Standard: IEC61000-3-2	

	harmonic wave current radiation	
	Limit value of Voltage fluctuation and flash	Standard: IEC61000-3-3
Use environment		No caustic gas, no dust.

Note:

- 1、 LM series PLC need to install on the metal fight with grounding, and please connect its ground wire to the metal fight directly. The cable should be connected along metal fight.
- 2、 When testing radiation emission, the device must be installed in metal shell with grounding to avoid disturbance. AC input power need to connect a filter or equivalent device and filter should be near module to avoid the EFT failure. Power wire of 24VDC power and sensor must be shielded.